

ROKAMAT
easy working

Tigris 850 CX

Art.-Nr. 53000

Tigris 1250 CX

Art.-Nr. 54000

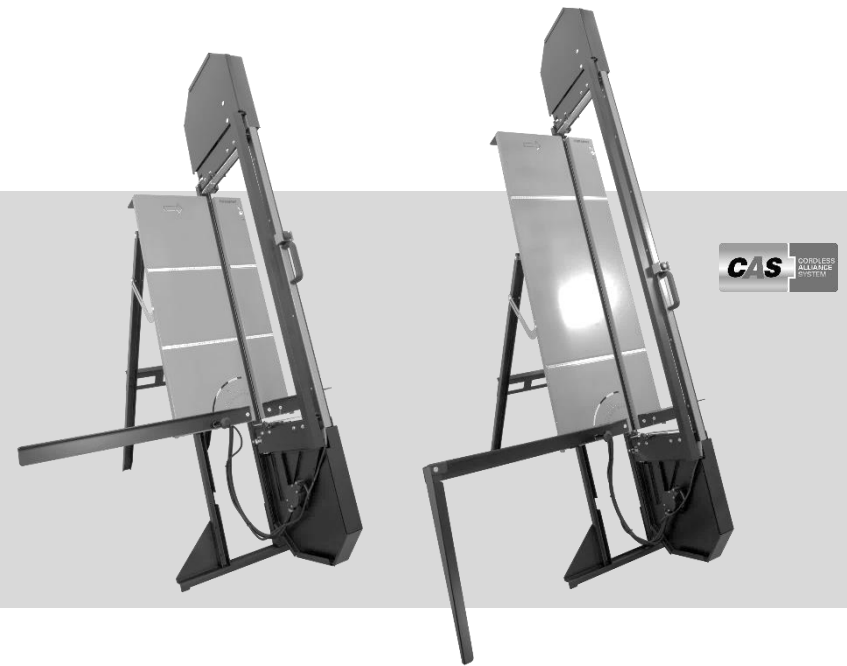

- 1) Rokamat Tigris 850 CX (24TICX850001)
Rokamat Tigris 1250 CX (24TICX1250001)
- 2) 2014/30/EU, 2006/42/EG, 2012/19/EU, 2011/65/EU,
EG No. 1907/2006
- 3) EN 62841-1:2015 + AC:2015 + A11:2022, EN ISO 12100:2010
- 4) Kammerer GmbH, An der B 10, 75196 Remchingen

Remchingen, 10.10.2024

Beate Kammerer
Head of Technical Documentation

© Kammerer GmbH. Printed in Germany. Abbildungen unverbindlich.
Technische Änderungen vorbehalten. BA_Tigris 850 CX_Tigris 1250 CX_EN_001

EN Original Instructions

4

ROKAMAT

Kammerer GmbH
An der B 10
75196 Remchingen
Deutschland



www.rokamat.com

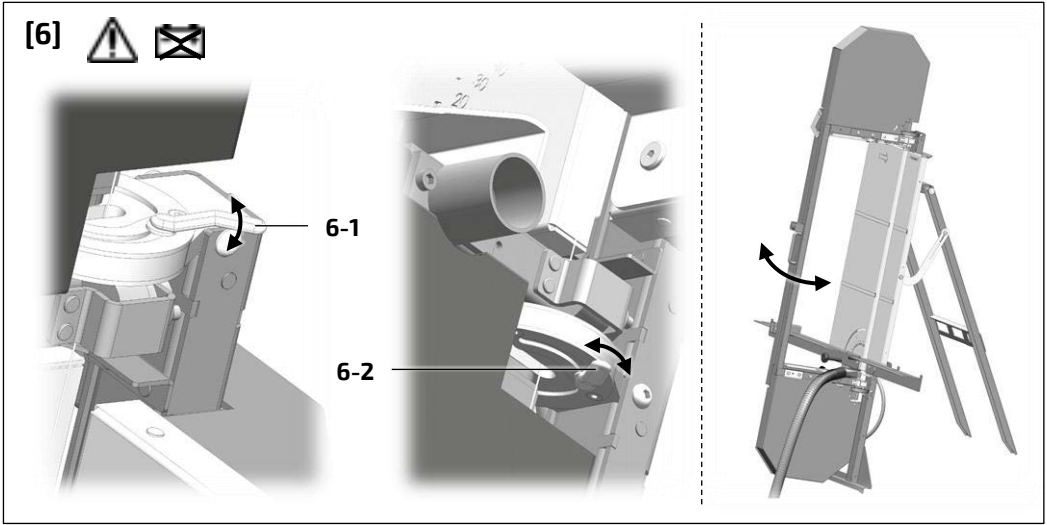
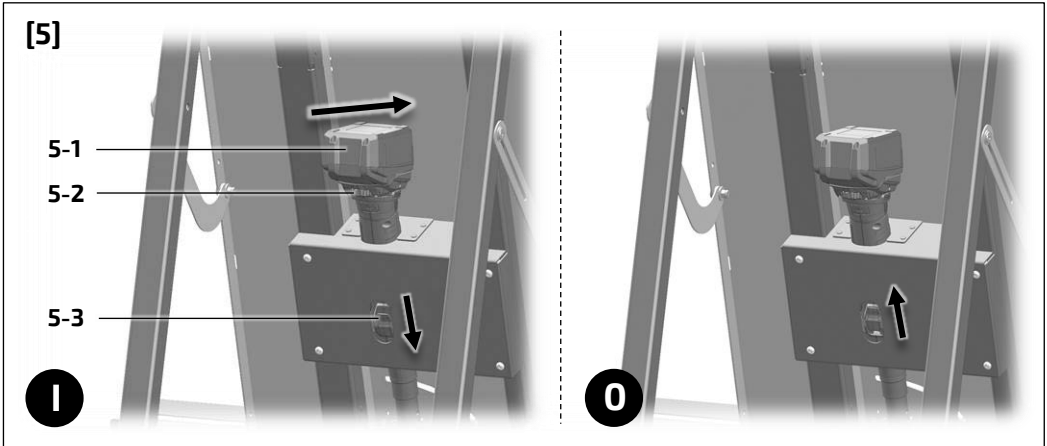
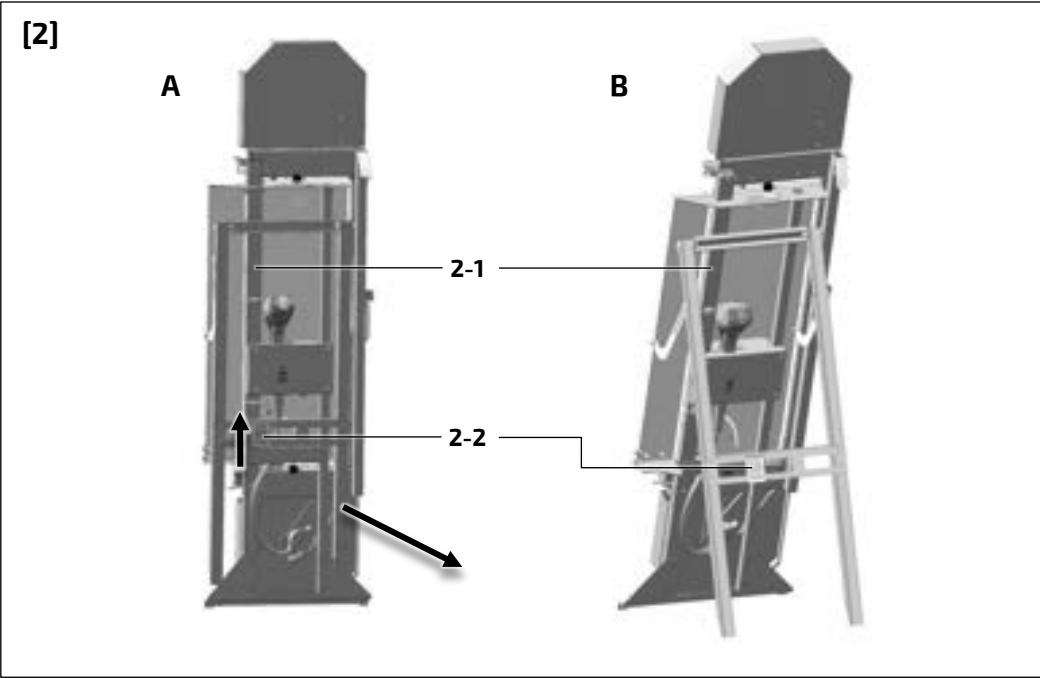
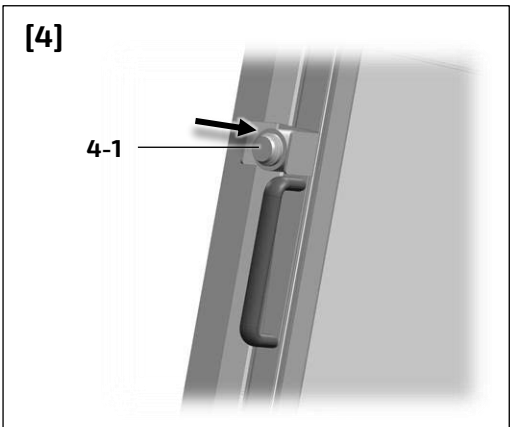
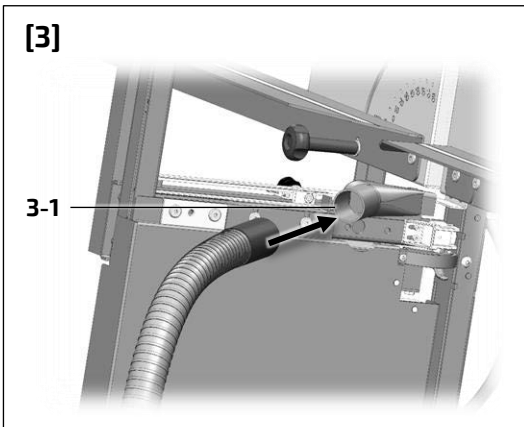
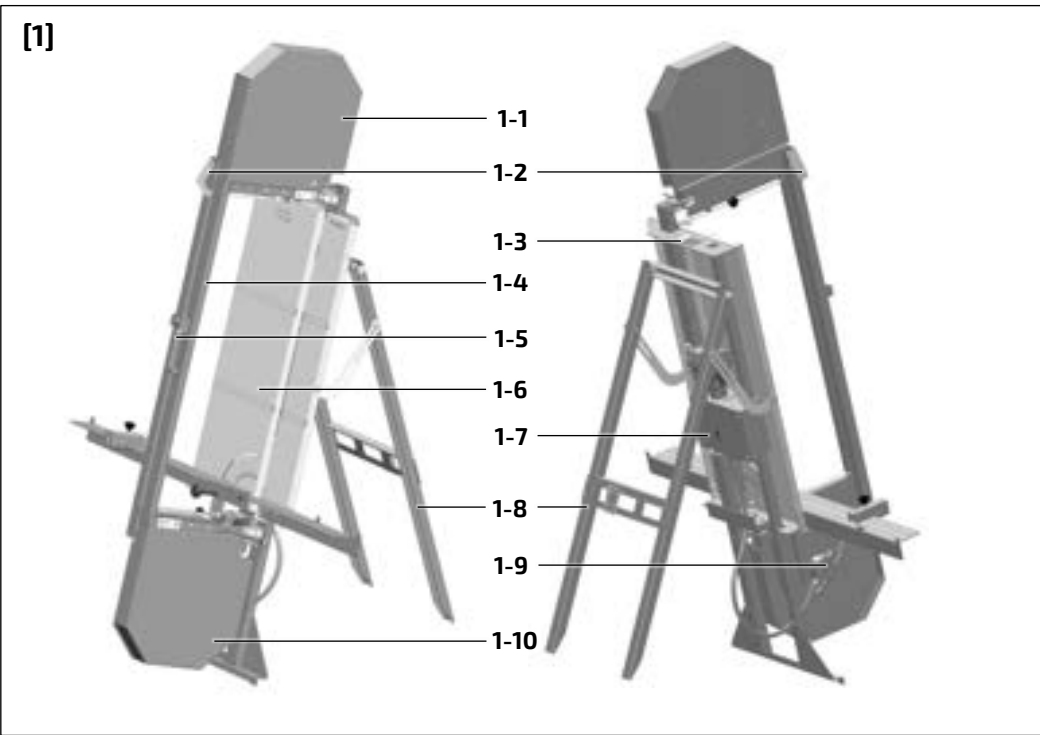

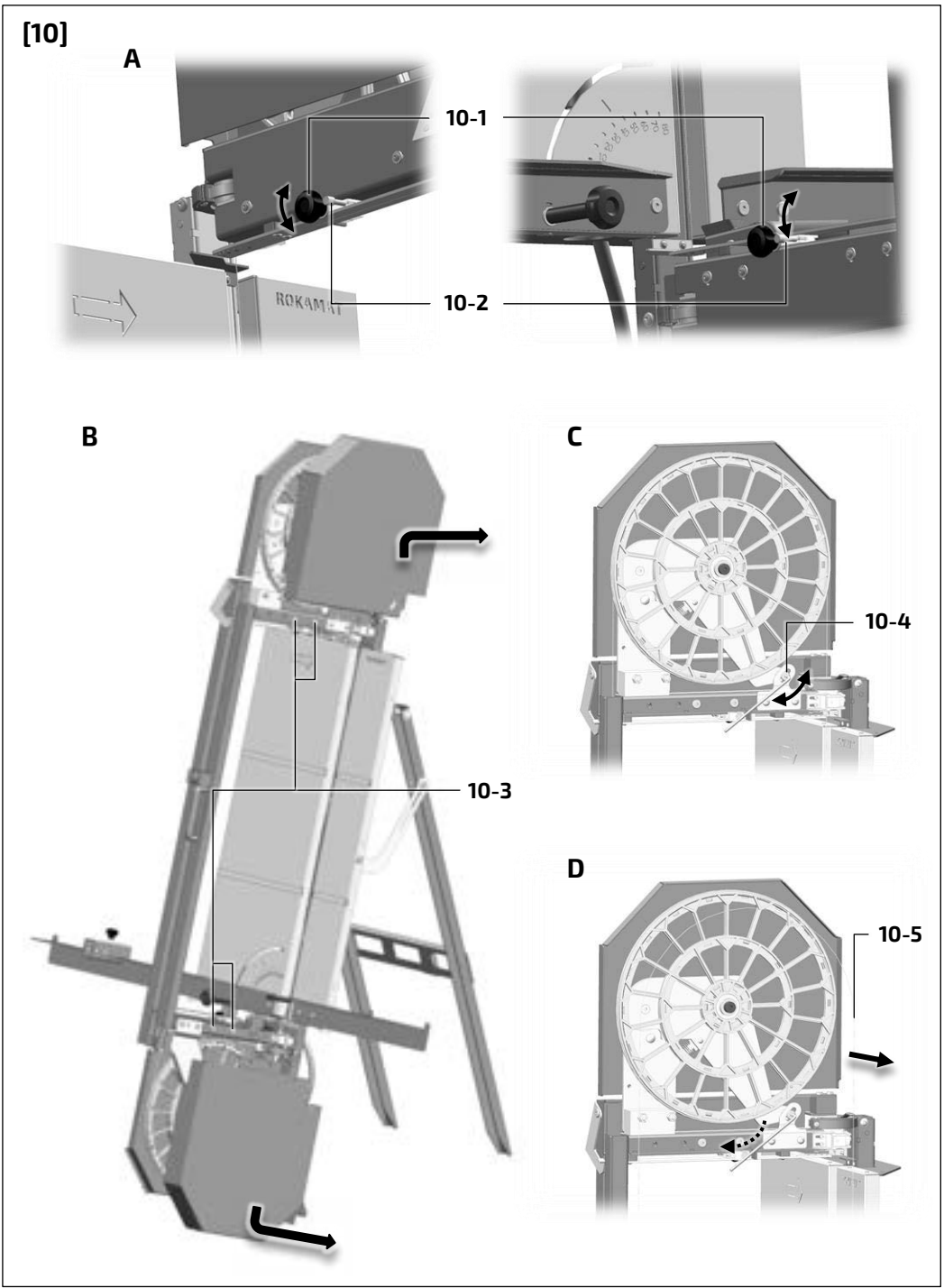
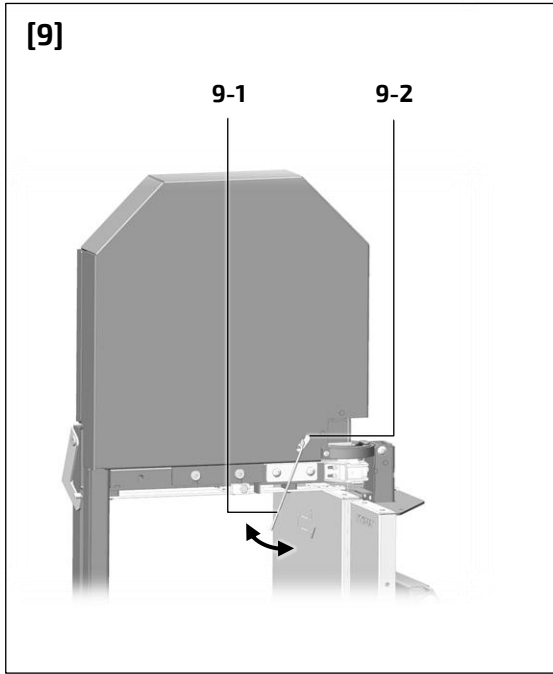
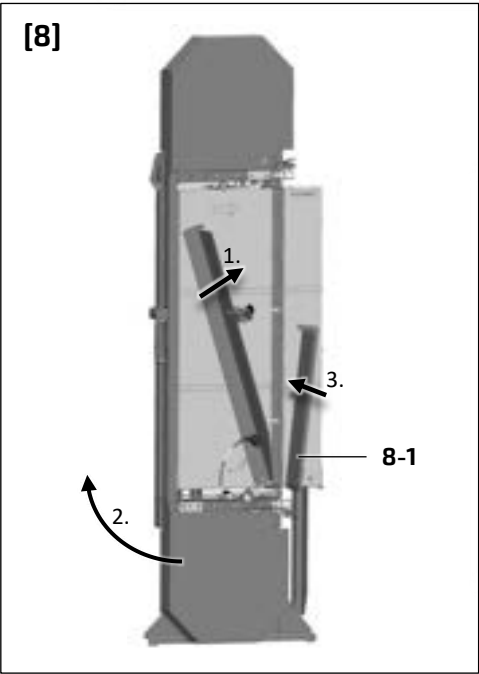
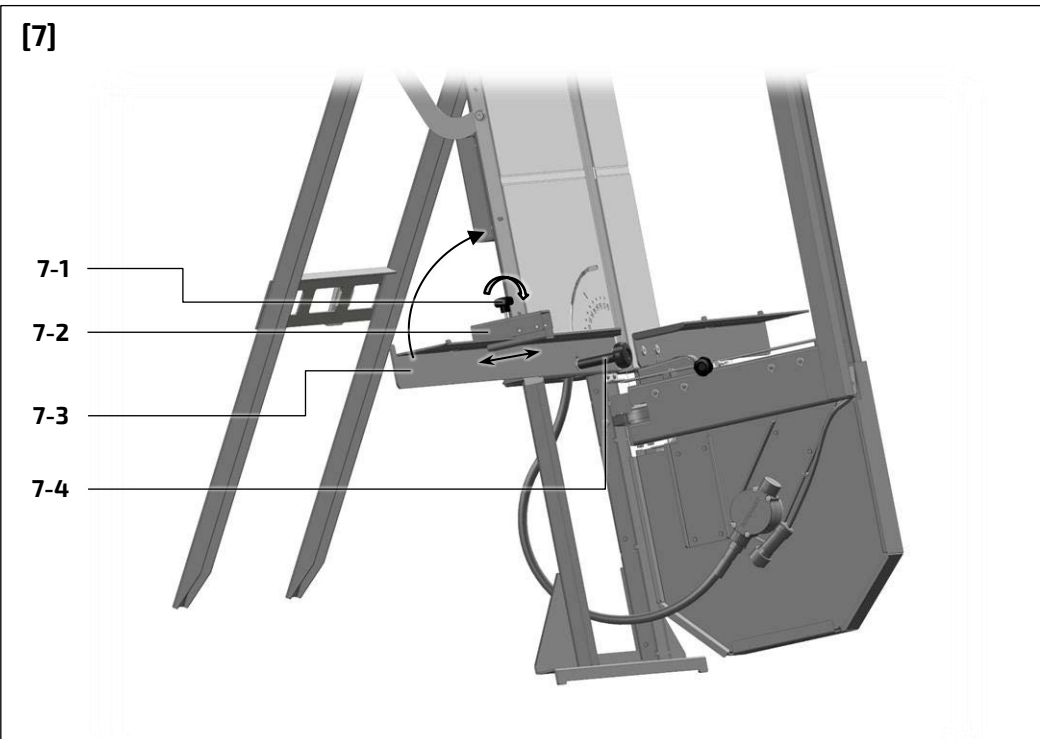

Contents

1. Symbols	4
2. Safety Instructions	4
3. Intended Use	4
4. Device Components	4
5. Commissioning	5
6. Instructions for Use	5
7. Maintenance and Care	6
8. Spare Parts and Accessories	6
9. Environmental Protection	6
10. Declaration of Conformity	6
11. Technical Specifications	6
12. Troubleshooting	6

11. Symbole



For your own protection and for the protection of your power tool, pay attention to all parts of the text that are marked with this symbol!



Risk of electric shock!



Warning of hand injuries! *)



Read operating instructions and safety notices! *)



Wear protective goggles!



Wear ear protection!



Wear hand protection!



Wear a dust mask! *)



CAS Li-Ion battery pack



Removing battery pack!



Do not dispose of as domestic waste! *)



Important advice/information



Direct Current (DC) *)



Confirms the conformity of the power tool with the directives of the European Community. *)



Confirms the conformity of the power tool with UK legislation. *)

*) These symbols are (also) on the device.

2. Safety Instructions

For your safety



WARNING!

Read all safety warnings and instructions.
Failure to follow all safety warnings and instructions may result in electric shock, fire and/or serious injury.



Do not use this power tool before you have thoroughly read and completely understood this Instruction Manual, the enclosed "General Safety Instructions", instructions for battery packs and chargers.

Keep all safety instructions and information for future reference. Pass on your power tool only together with these documents.

Please also observe the relevant national industrial safety regulations.

Safety instructions for wire saws

Do not reach into the area of the saw wire when the tool is switched on.

Only make the saw cuts using the handle provided for this purpose and at the same time secure the workpiece (insulation material) by hand.

Only use suitable materials.

If the impeller tensioner is already at the end stop, the impellers must be switched.

If the cutting speed decreases, the saw wire should be replaced.

A damaged or worn saw wire must not be used.



If the saw wire jams in the workpiece (insulation material), switch off the motor immediately. Before switching on again, the saw wire must be able to rotate freely again.

Before operating the wire saw, check that it is stable and that all machine parts are assembled correctly, especially all protective devices. Also check that the saw wire and impellers are in good condition and that the saw wire is sufficiently tensioned.

Additional safety instructions

Particles generated when working with this machine can be harmful to health. This dust must not

be allowed to enter your body. Do the following to reduce exposure to these sub-stances:

- Ensure good ventilation of the workplace
-  Wear suitable protective equipment, such as an FFP-2 protective mask.
-  Always wear protective goggles to protect against sanding hazards.
- Connect the electric power tool to a suitable extraction system.
- Sweeping or blowing stirs up dust.
- Vacuum or wash the protective clothing. Do not blow, beat or brush.

Collect the generated particles at the source, avoid deposits in the surrounding area.

Always use an antistatic suction hose with the power tool. A slight electric shock may cause you to panic briefly and become distracted, which may result in an accident.

switch off the machine immediately when the safety clutch responds and if the saw wire breaks!

Do not overload the motor for a long period. Engine noise should be regular (not wave-like). Unsteady engine performance can be perceived acoustically.

Take a break when the machine is heated up strongly and let it cool down again. To that let the motor idle at top speed for some time.

Don't bend the flexible drive shaft!

Only use original Rokamat saw wire. Foreign materials are not suitable for the saw wire speed and applications of the wire saw and could tear.

Emission levels

NOTE! Values for the A-weighted sound pressure level and for the total vibration values can be found in the "Technical specifications" table at page 5.

The vibration emission level given in this information sheet has been measured in accordance with a standardized test and may be used to compare one tool with another. It may be used for a preliminary assessment of exposure.

CAUTION! The indicated measurements refer to new power tools. Daily use causes the noise and vibration values to change.

The declared vibration emission level represents the main applications of the tool. However, if the tool is used for different applications, with different accessories or poorly maintained, the vibration emission may differ. This may significantly increase the exposure level over the total working period. However, if the tool is used for different

applications, with different accessories or poorly maintained, the vibration emission may differ. This may significantly decrease the exposure level over the total working period.



CAUTION! The noise produced during work may damage your hearing.
Wear ear protection!

Environmental conditions

Operation

Temperature range: +5° C to +50° C

Humidity: ≤ 85 %, non-condensing

Climate: dry

Transport and storage

Temperature range: -5° C to +55° C

Humidity: 0 % to 70 %

Climate: dry, roofed, dew protected

3. Intended Use

The portable cordless wire saws **Rokamat Tigris 850 CX** and **Tigris 1250 CX** are intended exclusively for cutting insulation materials and plasterboard at angles of 30°-90°. Insulation materials up to a max. thickness (cutting depth) of 340 mm, a max. width (cutting length) of 1200 mm and a max. density of 650 kg/m³ can be cut using only the Rokamat special wire saw. and may only be operated with an external dust extraction device.

The transportable wire saw must be set up on a level and solid surface and may only be operated with an external dust extraction device.

Only sufficiently qualified and trained personnel may carry out activities with the *Tigris CX*.

The intended use includes the observance of the operating instructions, in particular the safety instructions and the observance of generally recognized accident prevention regulations.

The manufacturer is not liable for damage caused by non-intended use of the tool.

4. Device Components

The specified illustrations can be found in Fig. [1] on page 2 of the operating manual.

- 1-1 Hood, top
- 1-2 Locking device for cutting bow
- 1-3 Holder Allen key set
- 1-4 Cutting bow
- 1-5 Handle
- 1-6 Support plate

- 1-7 Motor housing
- 1-8 Folding foot
- 1-9 Mitre-gear
- 1-10 Hood, bottom

5. Commissioning



WARNING!

Before switching on the power tool: Unpack power tool and accessories and check that no parts are missing or damaged.

Setting up the wire saw [2]



CAUTION!

Risk of injury! Danger of tipping!

The portable wire saw must be set up on a *level and firm* surface.

Freestanding

- A** Slide the locking [2-2] on the rear of the wire saw upwards.
- B** Fold out the folding foot [1-8] completely.

Assembly on the frame

Alternatively, the *Tigris CX* can also be mounted on a frame. To do this, place the unit upright on the scaffold (leave the stand and anti-tip guard in the starting position - as in Fig. [2 A]). Then lash the main carrier [2-1] to the rear of the frame using the two lashing straps supplied. Check that it is securely held!

Once the *Tigris CX* has been set up securely, the next step is to unfold the right-hand support bracket so that the cutting bow can be positioned at 0°. Finally, fold out the left-hand support bracket.

Connecting the dust extraction system [3]

Push the suction hose onto the intake socket [3-1]. Check for correct fit! If necessary, use a suitable adapter. See also chapter 6: "Dust extraction".

Switching the *Tigris CX* on and off [5]

Switching on: Insert the charged battery pack [5-1]. Set the toggle switch on the housing [5-3] to I.

Switching off: Set the toggle switch on the housing [5-3] to 0.

6. Instructions for Use



WARNING!

Risk of injury, electric shock!

Always remove the battery pack before performing any type of work on the machine!

Installing or removing battery pack [5]

To insert: Slide the battery pack [5-1] in until it engages.

To remove: Press the battery pack [5-1] release button and pull the battery pack out.

Starting the wire saw [4]

Switching the electric power tool on (see "Switching the *Tigris CX* on and off" in chapter 5). To start the wire saw (cutting), keep button [4-1] on handle [1-5] pressed - the saw wire starts moving.

Release the button [4-1] again to stop the saw wire.

Sawing insulating material



CAUTION!

Possible damage to the wire saw!

When making horizontal cuts, always push the insulation material through *from left to right* only!

An accessory set (item no. 53700 or 53702) is required for sawing *wood fiber*.

Before the saw wire can be inserted into the workpiece, it must have reached the *full* previously set speed.

Place the insulation material on the support plate [1-3] and the support bracket and make all necessary adjustments. Activate the wire saw (see "Starting the wire saw"). The cutting bow [1-4] can be moved using the handle [1-5]. It is possible to cut both by pushing and pulling the cutting bow [1-2]. In addition, if the cutting bow [1-4] is fixed (see "Length stop"), the insulation material can also be pushed from left to right in order to cut it horizontally.

Adjusting the cutting angle

Mitre cuts [6]: Loosen the quick release top [6-1] and bottom [6-2], adjust the cutting bow [1-4] to the desired angle (see miter indicator), fix the quick release [6-1 and 6-2] again.

Bevel cuts [7]: To move the left support angle [7-3], loosen the star grip screw [7-4]. Set the desired angle using the scale on the support plate [1-6] and tighten the star grip screw [7-4] again.

Length stop [7]

Bei Schnittwiederholungen kann der Anschlag [7-2] genutzt werden, um das gewünschte Maß am Auf-lagewinkel einzustellen.

Hierzu Sternschraube [7-1] lösen, Anschlag [7-2] auf gewünschte Position verschieben und Sternschraube [7-1] wieder festziehen.

Height stop [10-A]

Move out the cutting bow [1-4]. Loosen the star grip screw [10-2] at the top and bottom and slide the depth limit to the desired dimension (see scale on the cutting bow). Then retighten the star grip screws [10-2]. Now move the cutting bow [1-4] to the height stop and engage the fixing bolt [10-1] at the top and bottom to the right.

Locking device for cutting bow

The locking device [1-2] holds the cutting bow [1-4] in the extended position. This makes it easier to place larger insulation boards on the wire saw. To do this, fully extend the cutting bow, press the locking device to the right and only release it again when the cutting bow is retracted as far as the stop.

Adjusting the speed [5]

Set the recommended speed using the thumbwheel [5-2]. (Lower number = lower speed; higher number = higher speed).

Foot switch (optional)

Instead of the button [4-1] on the handle, the wire saw can also be started with the foot switch (optionally available).

First remove the plug of the hand switch from the socket on the motor housing [1-7] and then connect the foot switch. Then press the foot switch to start the wire saw.

If the foot switch is no longer actuated, the saw wire comes to a standstill again.

Support (only for *Tigris 1250 CX*)

The *Tigris 1250 CX* has an additional variable support on the left-hand support bracket to support the weight of larger insulation boards. If the left support bracket is set to 0°, the support must be

folded out far enough for stabilization so that it touches the floor and thus supports the support bracket.

Tensioning the saw wire [9]

As soon as the tension on the saw wire is decreased, perform the following steps:

- A** Insert the enclosed Allen wrench [9-1] into the opening [9-2] of the top cover [1-1] and turn the clamping screw inside *counterclockwise*. This allows the spring to tension the saw wire again.
- B** Then tighten the clamping screw *clockwise* again.

The optimum tension is achieved when the saw wire can be moved 25 mm forwards and backwards without effort.

Changing the saw wire [10]



WARNING!

Risk of injury! Warning of hand injuries!

Wear gloves when changing the saw wire to avoid cutting yourself!

- A** Lock the cutting bow [1-4] using the star grips [10-2] between a height of 60-100 mm.
- B** Loosen the screws [10-3] of the top and bottom hoods [1-1 and 1-9] (without removing them) and remove the covers upwards or respectively downwards.
- C** Use the enclosed Allen wrench to loosen the clamping screw [10-4]. Pull the upper saw wheel down to relax the wheel suspension (and thus the wire rope). Tighten the clamping screw again in this position.
- D** Put (worn) saw wire [10-5] over the saw wheels to remove it.

Insert the *new* saw wire into the groove of the upper saw wheel and then put it onto the lower saw wheel. Ensure that the saw wire is inserted correctly in all guides. Tension the saw wire (see "Tensioning the saw wire") and then attach the hoods in reverse order to the previous procedure.

Dust extraction



WARNING!

Health hazard posed by dust!

Where required, always work with an extraction system and wear a protective mask. Observe national regulations.

The dust extraction system offered on our website is adapted to the quantity of dust generated and permanently ensure the necessary suction power.

Transport [7 + 8]

	WARNING!
Risk of injury! Transport and storage of the power tool only in the carry bag. Keep these out of the reach of children. Children may suffocate or be strangled when playing with the carry case.	



To prepare the wire saw for transport, set the left support bracket [7-3] to 80° and the cutting bow [1-4] to 0° (fold in). Then fold up the right support bracket [8-1]. At the end fold in the folding foot [1-8] and slide the locking [2-2] downwards.

Remove the battery pack from the machine when transporting.

After work

	CAUTION!
Possible damage to the battery pack! Always switch the device off after use (see "Switching the <i>Tigris CX</i> on and off") to avoid deep discharge of the battery.	

7. Maintenance and Care

  	WARNING!
Risk of injury, electric shock! Always be sure that the tool is switched off and the battery pack is removed before performing maintenance work on the machine!	

Repairs may be carried out by an authorized customer service center only.

Regularly check the saw wheels to avoid danger and have them replaced by an authorized service workshop if they are damaged.

The power tool, especially the controls and inner lining of the saw wheels, should be cleaned regularly, often and thoroughly through all air vents using a vacuum cleaner or by blowing in dry air. Prior to this operation, separate the power tool from the power source and wear protective glasses and dust mask.

	ADVICE!
Check all wearing parts once a month.	

8. Spare Parts and Accessories

Other accessories, in particular insertion tools, can be found in the manufacturer's catalogues. Exploded drawings and spare-part lists can be found on our homepage: www.rokamat.com.

Use only original Rokamat spare parts and work tools!

9. Environmental Protection

The generated sawing dust may contain harmful substances. Dispose appropriately.

Observe national regulations on environmentally compatible disposal and on the recycling of disused machines, packaging and accessories.



For Great Britain and EU countries: Do not dispose of electric equipment or battery pack together with household waste material! In observance of the European Directives, on Waste Electric and Electronic Equipment and Batteries and Accumulators and Waste Batteries and Accumulators and their implementation in accordance with national laws, electric equipment and batteries and battery pack(s) that have reached the end of their life must be collected separately and returned to an environmentally compatible recycling facility.

	ADVICE!
Please ask your dealer about disposal options!	

10. Declaration of Conformity

It is expressly declared that the cordless wire saw listed on the first page under 1) from the indicated serial no. complies with all relevant provisions 2) and that the harmonized standards listed in 3) have been applied. The technical documentation is available from the authorized documentation agent named in 4).

11. Technical Specifications

Cordless wire saw	<i>Tigris 850 CX</i> Item no. 53000	<i>Tigris 1250 CX</i> Item no. 54000
Rated voltage	18 V DC	
Maximum saw wire speed	37 m/s	
Total weight	26,0 kg	31,0 kg
Space requirement	ca. 1,3 m ²	
Cutting length	850 mm	1250 mm
Board thickness	340 mm	
Dimension compact (LxWxH)	approx. 200x560x1850 mm	approx. 200x560x2250 mm
Dimension set up (LxWxH)	approx. 1100x1200x1850 mm	approx. 1100x1200x2250 mm
A-weighted sound pressure level (see cap. 2 "Emission levels"):		
Sound pressure level L _{PA}	87 dB(A)	
Sound power level L _{WA}	92 dB(A)	
Uncertainty K _{PA} , K _{WA}	3,0 dB	
Total vibration value (see cap. 2 "Emission levels"):		
Emission value a _h	< 2,5 m/s ²	
Uncertainty K	1,5 m/s ²	

12. Troubleshooting

Problem	Possible causes	Remedy
Motor runs, but the saw wire does not turn.	Shaft core broken.	Exchange shaft core.
	Mitre gear is defective.	Replace mitre gear.
<i>Tigris CX</i> not working.	Battery discharged.	Charge battery.
Saw wire vibrates or has too little tension.	Not enough tension.	Tension the saw wire again.
Cutting speed decreases.	Saw wire worn out.	Remove blockage.
Extraction power is insufficient.	Suction nozzle blocked.	Clean the filter element regularly.

If problems other than those listed occur, please contact your ROKAMAT service workshop or your local specialist.