

Original Operating Manual

Block saw BS-750



Device Name: Block saw BS-750
Device Number: Nameplate
Year of Manufacture: 2018
Country of Manufacture: Czech Republic
Read the operating manual before putting into operation!



1 Table of Contents

1	Table of Contents	2
2	General	5
2.1	Foreword	5
2.2	Address	5
2.3	Version status	5
2.4	Typographic conventions	6
2.5	Customer service.....	8
2.6	Limitation of liability.....	9
2.7	Copyright.....	10
2.8	Disposal.....	10
2.9	Conformity.....	10
2.10	Personnel requisition	11
2.10.1	Fundamentals	11
2.10.2	Instructed personnel	11
2.10.3	Qualified personnel.....	11
2.10.4	Qualified electricians.....	11
2.10.5	Unauthorized persons.....	11
3	Safety	12
3.1	General	12
3.2	Intended use.....	12
3.3	Non-intended use	12
3.4	Responsibility of the operator.....	13
3.4.1	Operator.....	13
3.4.2	Responsibilities of the operator	13
3.5	Responsibility of the personnel	14
3.6	Personal safety equipment.....	15
3.7	Residual risks	16
3.7.1	Hazard and notice signs	16
3.7.2	Special safety instructions	16
3.8	Machine areas	17
3.9	Dangers	18
3.9.1	Risks due to moving parts	18
3.9.2	Risks from thermal hazards.....	18
3.9.3	Risks due to electrical voltage	19
3.9.4	Risks due to vibrations.....	19
3.9.5	Risks due to noise	19
3.10	Protective devices	20
3.10.1	Emergency stop button.....	20
3.10.2	Blade guard	21

3.10.3	Main switch with emergency off function	22
3.11	Actions in case of danger and accident.....	23
3.11.1	Preventative measures	23
3.11.2	Handle accidents properly	23
3.12	Spare parts	23
4	Technical data.....	24
4.1	Environmental conditions	24
4.2	Block saw BS-750	24
4.3	Name plate.....	25
5	Construction and function	26
5.1	Machine overview	26
5.2	Functional description	27
5.3	Operating and display elements	28
6	Transport and storage.....	29
6.1	Delivery	29
6.2	Transport	29
6.2.1	Transport inspection	29
6.2.2	Transport symbols	30
6.3	Transport in-plant	31
6.4	Storage	32
6.4.1	Storage conditions	32
6.5	Handling packaging materials.....	33
7	Setup.....	34
7.1.1	Notes on setup.....	34
7.2	Electrical connection.....	35
8	Operation.....	36
8.1	Notes on operation	36
8.2	Clamping / changing the cutting blade	37
8.3	Filling the cooling water	40
8.4	Turn on the Block saw BS-750	41
8.5	Cutting process	42
8.6	Switch Off	44
8.6.1	Pause.....	44
8.6.2	Shutdown	45
8.7	Shutdown in emergency	46
8.7.1	Measures before restarting after an emergency stop.....	46
8.8	Settings.....	47
8.8.1	Setting the cutting depth	47

8.8.2	Adjusting the cutting blade	48
9	Maintenance and cleaning	56
9.1	Maintenance	56
9.1.1	Notes on maintenance.....	56
9.1.2	Maintenance plan	57
9.1.3	Measures after Maintenance is Carried Out.....	58
9.2	Maintenance work.....	59
9.2.1	Emptying the cooling water tank.....	59
9.2.2	Clean the water fork.....	60
9.3	Cleaning.....	61
9.3.1	Cleaning the machine.....	61
10	Faults	62
10.1	Actions in case of faults	62
10.2	Process related faults	63
11	Removal and disposal.....	64
11.1	Notes on removal and disposal	64
11.2	Disposal.....	64
12	Indices	65
12.1	Table of Figures	65
12.2	List of tables.....	66
13	Annex.....	67
13.1	Declaration of conformity within the meaning of the Machinery Directive 2006/42/EC Annex II 1A	68
13.2	Circuit diagram for the Block saw BS-750	69
13.3	Replacement parts list	70

2 General

2.1 Foreword

This operating manual applies exclusively to the machine designated in the title.

This operating manual provides important information for the safe and efficient use of the machine. It is an integral part of the machine and must be kept in readable condition for the personnel working on it, in the immediate vicinity of the machine at all times.

The operating manual is a foundation for any work with the machine. A requirement for safe operation of the machine is the adherence to all of the safety and operation instructions provided. Personnel must, therefore, have carefully read this operating manual before beginning any work.

In addition, the national accident prevention regulations applicable at the place of use of the machine and the general safety provisions must be observed.

The operating manual is a foundation for any training on the machine.

2.2 Address

Dr. Schulze s.r.o.
Hulínská 1814/1B
76701 Kromeriz
Czech Republic
Tel.: +420 573 331 309
E-Mail: obchod@lestet.de
Fax: +420 573 336 101
Website: www.lestet.cz

2.3 Version status

Table 1: Version status

Date	Chapter	Reason	Version	Prepared
04/12/2018	Complete Document	New Version	1.0	Technische Dokumentation CE

2.4 Typographic conventions

To be able to work optimally with the operating manual the following, please note the following explanations of the typographical conventions.

Numbering

- Bullet points of the first level.
 - Bullet points of the second level.

Handling instruction

1. Step 1 of the operating sequence
2. Step 2 of the operating sequence
3. Step 3 of the operating sequence

The sequence of the work steps must be observed.

Warning and safety instructions

The following symbols are used in this operating manual to illustrate hazards and notices:



Danger

... indicates an immediate risk, which leads to death or serious injuries, if it is not avoided..



Warning

... indicates a possible hazardous situation, which can lead to death or serious injuries, if it is not avoided.



Caution

... indicates a possible hazardous situation, which can lead to light injuries, if it is not avoided.



Attention

... indicates a possible hazardous situation, which can lead to property damage, if it is not avoided.



Note

... provides tips and recommendations, as well as information for efficient and fault-free operation.

2.5 Customer service

Our customer service department is available to provide technical details.

You can obtain information regarding the contact persons for your region by telephone and at any time by fax, e-mail or via the Internet.

In addition, our personnel are always interested in any of your experiences and new information arising from your use of the equipment, which can be useful for the improvement of our products.

Dr. Schulze s.r.o.

Hulínská 1814/1B

76701 Kromeriz

Czech Republic

Tel.: +420 573 331 309

E-Mail: obchod@lestet.de

Fax: +420 573 336 101

Website: www.lestet.cz

2.6 Limitation of liability

All information and instructions in this operating manual were written while taking account of the applicable standards and regulations, the current state of technology and our many years of knowledge and experience. The obligations agreed in the delivery contract, the general terms and conditions as well as the delivery conditions of the manufacturer and the legal regulations valid at the time of the conclusion of the contract apply.

The manufacturer assumes no liability for damage due to:

- Failure to comply with this operating manual,
- unintended use,
- use of untrained and non-instructed personnel,
- unauthorized modifications and technical changes,
- use of unauthorized spare parts.

The actual scope of delivery can differ from the explanations and figures shown here in the case of special designs, the use of additional options or the latest technical modifications.

We reserve the right to make modifications to improve the characteristics of use and for further development.

2.7 Copyright

Dr. Schulze GmbH holds the copyright for the operating manual.

The operating manual includes instructions and diagrams or diagram sections of a technical nature, which may not be reproduced in the entirety or in part, distributed or used for competition purposes or otherwise communicated.

The creation of copies – even in part – is permitted for the operator of the machine expressly only for internal use in connection with operation of the machine. Dr. Schulze GmbH reserves all rights for the licensing of use for publication or distribution of copies or information from this operating manual to third parties.

In case of infringement the manufacture is entitled to make a claim for damages. Further claims are reserved.

2.8 Disposal

The operating manual is a component of the machine.

The operating manual must be provided when disposing of the machine.

2.9 Conformity

The relevant guidelines (with their accompanying modification guidelines) in the version applicable at the date of commissioning have been taken as the basis for the conformity assessment. The guidelines, to which it relates in particular, can be found in the conformity statement.

The conformity statement is in the appendix.

2.10 Personnel requisition

2.10.1 Fundamentals

Any activities on the machine may only be performed by persons who are able to carry out their work properly and reliably and who meet the specified requirements in each case.

Please note the following:

- Persons, whose reaction times are influenced by, e.g. drugs, alcohol or medications, may not carry out any work.
- Always observe the age and profession specific guidelines when appointing personnel.

2.10.2 Instructed personnel

Instructed personnel are those who have been trained fully and demonstrably by the operator in the duties entrusted to them and any possible dangers.

2.10.3 Qualified personnel

Qualified personnel include those, who on the basis of the occupational training, knowledge and experience of the relevant regulations are in a position to carry out the work assigned to them properly, recognize possible dangers independently and avoid personal or property damage.

Their tasks include scheduled maintenance to reduce and avoid incidents.

2.10.4 Qualified electricians

An qualified electrician is anyone who, due to his professional training, knowledge and experience and knowledge of the relevant provisions, is able to perform work on electrical equipment properly. Furthermore, he recognizes potential dangers independently and can avoid personal injury and property damage due to electrical voltage.

All work on the electrical equipment may, as a matter of principle, only be carried out by qualified electricians.

2.10.5 Unauthorized persons

Unauthorized persons are not admitted. They do not know the dangers in dealing with the machine and must be accosted in case of doubt and removed from the work area.

3 Safety

3.1 General

This section gives an overview of important safety aspects for the protection of the user and the operators. The instructions indicate possible dangers and serve the safe and trouble-free operation of the plant.

Where the operating, warning and safety instructions provided are not observed, considerable risks can arise.

3.2 Intended use

The Block saw BS-750 is conceived, depending on the material, for wet or dry cutting. It is exclusively designed for the division of large-scale mineral construction materials such as artificial or natural sandstone, washed concrete, concrete blocks and aerated concrete. It is designed for continuous use on building sites or in factories and may only be used for industrial purposes and only operated by trained personnel. The Block saw BS-750 may only be used in accordance with the environmental conditions listed in the Technical Data. The machine may only be operated by one person!

Proper use requires compliance with the instructions

- for safety,
- for operation,
- for servicing/maintenance,
- per the technical specifications

which are described in this operating manual.

3.3 Non-intended use

The Block saw BS-750 may not be used for cutting metal and wood.

Any other use beyond its intended use is considered improper use. The operator of the machine is liable for any damage resulting from this.

3.4 Responsibility of the operator

3.4.1 Operator

The operator is any natural or legal person who uses the machine or gives it to third parties for use. The operator is responsible for the safety of the users or third parties during use.

3.4.2 Responsibilities of the operator

The machine is used for industrial purposes. The operator is therefore subject to the statutory obligations for occupational safety.

Safety for persons can only be guaranteed, if all of the required measures are taken. It is the responsibility of the operator of the machine to organize these measures, to implement them and to verify their execution.

In particular, the operator must:

- provide information about applicable health and safety regulations.
- ensure that the labels and signs on the machine indicate hazardous spots and are legible. damaged or unrecognizable labels and signs must be replaced by the operator immediately.
- ensure that the workplace lighting is in accordance with national and local regulations.
- determine by means of a risk assessment any possible additional hazards, which result from the special conditions of use at the place of use of the machine.
- implement in the operating instructions the required behavioral requirements for the operation of the machine in the place of use.
- during the entire period of use of the machine regularly check, whether the operating instructions correspond to the current state of the regulatory framework. if necessary, amend the operating instructions to new regulations, standards and conditions of use.
- unambiguously and clearly determine the responsibilities for the installation, operation, maintenance and cleaning of the machine.
- ensure, that all personnel involved with the machine have read the operating manual. In addition, they must train personnel in the standard distances to maintain when operating the machine and inform them of the hazards.
- prepare for the personnel assigned to work with the machine the prescribed and recommended safety equipment.
- possibly other special regulations such as for machines used in wet environments, the provisions of the “Stone and Earth” professional association.

The operator is also responsible for ensuring that the machine

- is always in a technically fault-free condition.
- is maintained in accordance with the prescribed maintenance intervals.
- all safety equipment on the machine is regularly inspected for completeness and functionality.

3.5 Responsibility of the personnel

In addition to the warning and safety notices in this operating manual, the safety, accident prevention and environmental protection provisions applicable to the place of use must also be observed.

In particular, it is the case that personnel:

- inform themselves regarding the applicable occupational safety regulations.
- implement the behavioral requirements provided in the operating instructions for operating the machine in the place of use.
- observe the allocated responsibilities for the operation, maintenance and cleaning of the machine properly.
- must have fully read and understood the operating manual before the commencement of work.
- the prescribed personal protective equipment applies. It must be checked regularly and replaced in case of damage. In particular, ear protection must be worn when operating the machine.
- Avoid abnormal postures when working. For all work, secure footing must be ensured, so that balance can be maintained at all times.
- Tools belonging to the device must be safely stored. They must not come loose during operation.

Furthermore, anyone who assigned to the machine in their range of responsibilities is responsible for ensuring that the machine

- is always in technically fault-free condition.
- is maintained in accordance with the prescribed maintenance intervals.
- all safety equipment is regularly inspected for completeness and functionality.
- Ensure that the machine is protected against unauthorized use after finishing work. It must be stored in a dry, locked room against unauthorized persons (e.g. children).
- Always pay attention to order and cleanliness in the work area, since loose surrounding objects can be accident sources.

3.6 Personal safety equipment

Personal safety equipment must be worn when working to minimize health hazards. For that reason:

- Wear protective equipment properly before starting work and wear it while working.



Protective Workwear

for protection against catching on moving machine parts.

Workwear is tight and with low tear resistance, with tight sleeves and no protruding parts.

Do not wear rings, necklaces or other jewelry.

For long hair, wear a hairnet.



Use of special cut-resistant work gloves to protect the hands against abrasion, grazes, scratches, scrapes, puncture wounds, piercing or similar injuries to the surface of the skin.



Safety Shoes

to protect the feet against injury by falling parts and against slips and falls on a slick surface.



Hearing Protection

for protection against hearing damage.



Protective Goggles

to protect against eye injuries due to flying parts, particles, sprays of liquid or escaping compressed air.



Face mask

to protect against damage caused by inhalation of dust and small particles.



Face Protection

to protect against face and eye injuries due to flying parts, particles, sprays of liquid or escaping compressed air.

3.7 Residual risks

3.7.1 Hazard and notice signs

The machine was subjected to a risk assessment. The identified hazards were, as far as possible, eliminated and acknowledged risks were reduced. The structurally unavoidable hazard points are marked by labels and signs. These must always be easy to read.

3.7.2 Special safety instructions



... indicates hazards due to electrical voltage.

Where safety notices are not observed there is a danger of serious or deadly injuries.

Responsibilities of the operator, installation of safety systems (RCD) that detect a short-circuit and isolate all connected phases.



... indicates hazards from hot surfaces.

Where safety notices are not observed there is a danger of burns and serious skin injuries due to heat.



... indicates hazards due to catching.

Failure to observe the safety instructions may result in hand injuries.



... indicates a risk of cutting due to rotating cutting blade.

Failure to observe the safety instructions will result in the risk of cuts and serious injury from a rotating cutting blade.



... indicates dangers due to trapping.

Where safety notices are not observed there is a danger of serious or deadly injuries.



... indicates that it may not be operated by persons with a pace-maker.

Where safety notices are not observed there is a danger of impairment to persons with a heart pace-maker.



... indicates a ban on carrying metal parts.

Carrying metal items, watches, magnetic or electronic data devices is forbidden, as the magnetic field can damage or destroy the items.

3.8 Machine areas

There are three different areas around the machine.

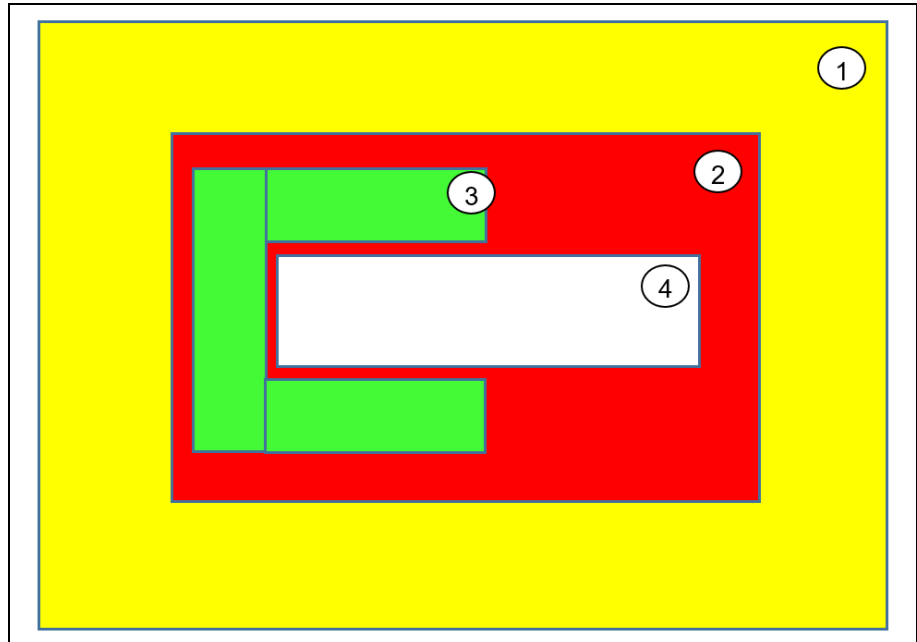

Figure 1: Machine areas on the Block saw BS-750

- | | | | |
|---|--------------|---|------------------|
| 1 | Traffic Zone | 3 | Work Zone |
| 2 | Danger Zone | 4 | Block saw BS-750 |

Work Zone

The area in which persons work with or operate the machine in normal operation; excludes inspection, maintenance, cleaning and repair.

The work zone (green area) may only be entered by authorized operational personnel to operate the machine.

Danger Zone

The person in which a person is faced with a risk of injury or hazards to their health.

The danger zone (red area) must be closed off and clearly marked and may not be entered by persons while the machine is being operated.

Traffic Zone

An area which is accessible for or open to persons without opening, crossing or bypassing a barrier.

The traffic zone (yellow area) must always be kept free and may only be used as a traffic route and for transport work.

3.9 Dangers

Observe the warning and safety instructions provided here and in the operating chapters of this manual without fail to avoid possible health hazards and dangerous situations.

3.9.1 Risks due to moving parts

Driven moving elements can present hazards that can lead to injury (such as bruising, pulling in of body parts).

Only operate the machine if all safety devices are installed and working properly. In particular, the blade guard must always be closed when operating the machine.

Before switching on the machine, make sure that nobody can be endangered by the starting machine. Nobody is allowed to access the running machine. Do not bring body parts into the area of moving parts when operating the machine. Always maintain a safe distance.

Switch off the power supply before entering the danger zone and secure it against being switched on again. Before starting work in the danger zone, always wait until the parts have come to a standstill and wait for the automatic removal of residual energy.

3.9.2 Risks from thermal hazards

The machine integrates parts / components that become hot during operation. There is a risk of burns when touching the hot surfaces. Wear appropriate personal protective equipment when working on hot parts (e.g. on motors).

Before doing any work, make sure that the parts/ components have cooled down.

3.9.3 Risks due to electrical voltage

Touching live parts can cause serious injury or even death. Therefore, work on electrical equipment may only be carried out by qualified electricians.

Before starting any work on electrical equipment, switch off the machine and check that there is no electrical voltage. Secure the power supply against re-start.

Check electrical equipment regularly for external damage (e.g. to the insulation) and loose connections to cable terminals. If any defects are detected, immediately switch off the power supply and arrange for repair.

The electrical equipment (e.g. as well as cables and plugs) must not come into contact with water.

Use only undamaged extension cables, which are designed for use in the respective environment and whose core cross-section is sufficiently dimensioned. Completely unroll a cable reel to prevent overheating. Protect the cable against heat, oil and sharp edges.

Do not bypass fuses or disable them. When inserting defective fuses always pay attention to the correct indication of the current intensity.

3.9.4 Risks due to vibrations

Strong vibrations can lead to damage to your health. Therefore, vibration dampers must not be disabled.

Do not stay in the area of heavily vibrating danger points during operation.

3.9.5 Risks due to noise

Refer to the Technical Data section for the emission level (sound pressure level) from the machine. Depending on local conditions, a higher sound pressure level may result, leading to damage to hearing or even hearing loss.

Therefore, the following applies:

From a sound pressure level of > 80 dB (A) at the workplace, the necessary personal protective equipment (ear protection) must be worn during all work.

3.10 Protective devices

The machine is built according to the applicable legal regulations and is safe to operate. Danger points not structurally excluded are provided with protective devices. When operating the machine, all protective devices must be present and functional.

Protective devices must not be changed or adapted.

3.10.1 Emergency stop button

The emergency stop button (1) is a push button. It is used to shut off the power supply and is depressed both for turning off and in case of danger.

After pressing the emergency stop button (1), the machine is switched off.

Before restarting the machine after an emergency situation, the cause must be eliminated.

The emergency off button (1) is unlocked by pulling out the cover.

The emergency off button (1) is on the control box of the Block saw BS-750.



Figure 2: Position of the emergency stop button on the Block saw BS-750

3.10.2 Blade guard

The machine may only be operated with the blade guard closed (1). This provides work safety.



Figure 3: Position of the blade guard on the Block saw BS-750

3.10.3 Main switch with emergency off function

Integrated in the control box are a main switch with emergency off function (1) a thermal overcurrent relay and an undervoltage release.

Green button - 1 = switch machine on

Red button - 0 = switch machine off

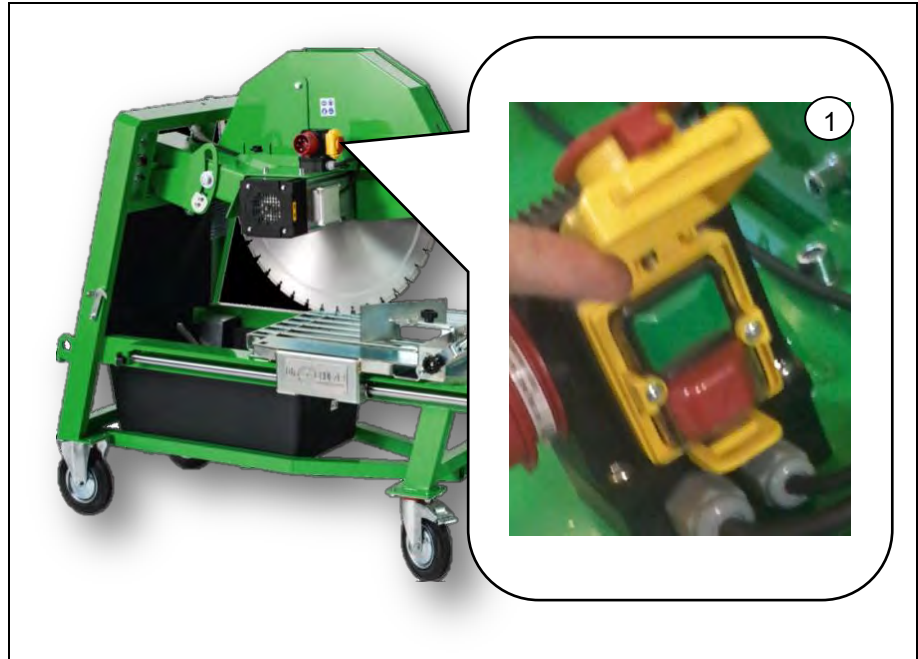

Figure 4: Position of the control box on the Block saw BS-750

A bimetallic overload protector protects the drive and prevent the restarting of the motor outside the permissible temperature range. An overload can occur, e.g. by overly fast cut, hard material, dull cutting blade or route of the cut. After the drive motor has cooled down (at least 10 minutes), the main switch (1) must be set to "0" / red before the machine can be restarted.

The built-in under-voltage release prevents, e.g. after a power failure, the accidental restart of the drive when voltage is applied again.

3.11 Actions in case of danger and accident

3.11.1 Preventative measures

In the event of danger, the following preventive measures must generally be taken:

- Always be prepared for accidents.
- Keep first aid equipment (first aid kit, blankets, etc.) and fire extinguishers at hand.
- Always keep the approaches for rescue vehicles free.

3.11.2 Handle accidents properly

In the case of an accident, the following rules of conduct should be observed:

- Immediately trigger emergency stop.
- Take first aid measures.
- Remove affected persons from the danger zone.
- Inform those in charge at the site.
- Call a doctor and/or the fire service in case of serious injuries.
- Always keep the approaches for rescue vehicles open.

3.12 Spare parts

Spare parts

Only spare parts specified by Dr. Schulze GmbH may be used. The information in the parts lists and/or spare parts lists is decisive in this case.

Other parts can influence the safety functions and the behavior of the machine. They may not, therefore, be used.

Date of use

Spare parts, which have exceeded the maximum date of use, may no longer be used.

4 Technical data

4.1 Environmental conditions

Table 2: Environmental conditions

Information	Value [unit]
Temperature range	-15 – 43 °C
Atmospheric humidity	60%

4.2 Block saw BS-750

Table 3: Technical data of the Block saw BS-750

Machine/System Information	Value [unit]
Drive motor (power)	4 [kW]
Voltage	3 × 400 [V] / 50 [Hz]
Rated current	9,6 [A]
Rotational speed of the cutting shaft	1494 [min ⁻¹]
Location hole	60 [mm]
Max. cutting blade diameter	650 / 700 / 750 [mm]
Max. cutting length	900 [mm]
Max. cutting depth	285 [mm] (without turning the material over)
Table length	593 [mm]
Table width	677 [mm]
Weight (approx.)	195 [kg]
Length	1800 [mm]
Width	810 [mm]
Height	1360 [mm]
Protection class	IP 55
Sound pressure level, measured	95 dB(A), must wear ear protection
Sound power level, measured	101 dB
Total vibration value / hand-arm vibrations	under 2,5 m/s ²
Volume of water container	80 [l]

4.3 Name plate

The rating plate is used to identify the component assembly. The specification of the type plate facilitates communication with the customer service.



Figure 5: Name plate

5 Construction and function

5.1 Machine overview

The Block saw BS-750 is designed so that the water cooling and splitting mechanism are fixed on the basic frame. The cutting table can be moved between its limit stops.

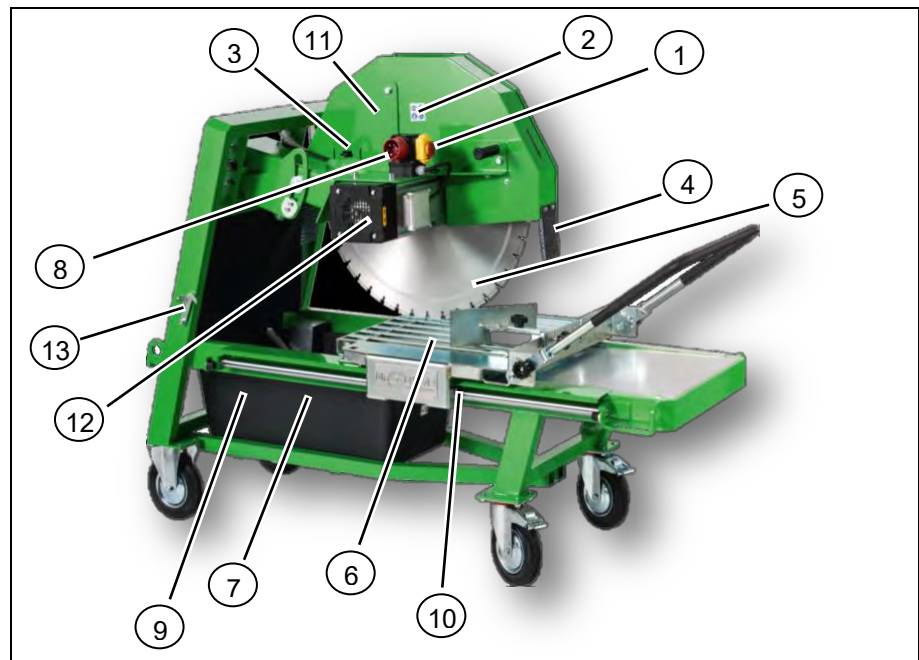

Figure 6: Block saw BS-750

- | | | | |
|----|---------------------------------|----|---------------------------|
| 1 | Control panel | 7 | Water pump (behind cover) |
| 2 | Blade guard | 8 | Socket - mains connection |
| 3 | Shut-off valve - cooling water | 9 | Water container |
| 4 | Spray guard | 10 | Guide carriage |
| 5 | Cutting blade | 11 | Cutting head |
| 6 | Cutting table | 12 | Drive motor |
| 13 | Cutting table locking mechanism | | |

5.2 Functional description

Depending on the material, the Block saw BS-750 can be used in wet or dry cutting.

The material is positioned on the cutting table.

During operation, the cutting table and material to be cut are manually guided towards the cutting disc with the aid of a handle. An electric pump ensures the cooling water supply during wet cutting. It transports the cooling water from the cooling water tank directly to the cutting blade. This increases the service life of the cutting blade and serves to bind dust. The shut-off valve on the blade guard closes the water supply during dry cutting.

The cutting head is held by a cutting head mount (1). The position of the cutting head can be adjusted via the screw (2) and the catch (3). This allows the cutting blade to be positioned for full or reduced depth of cut. This guarantees a uniform cutting depth over the entire cut. Use the tools supplied (4) for this.

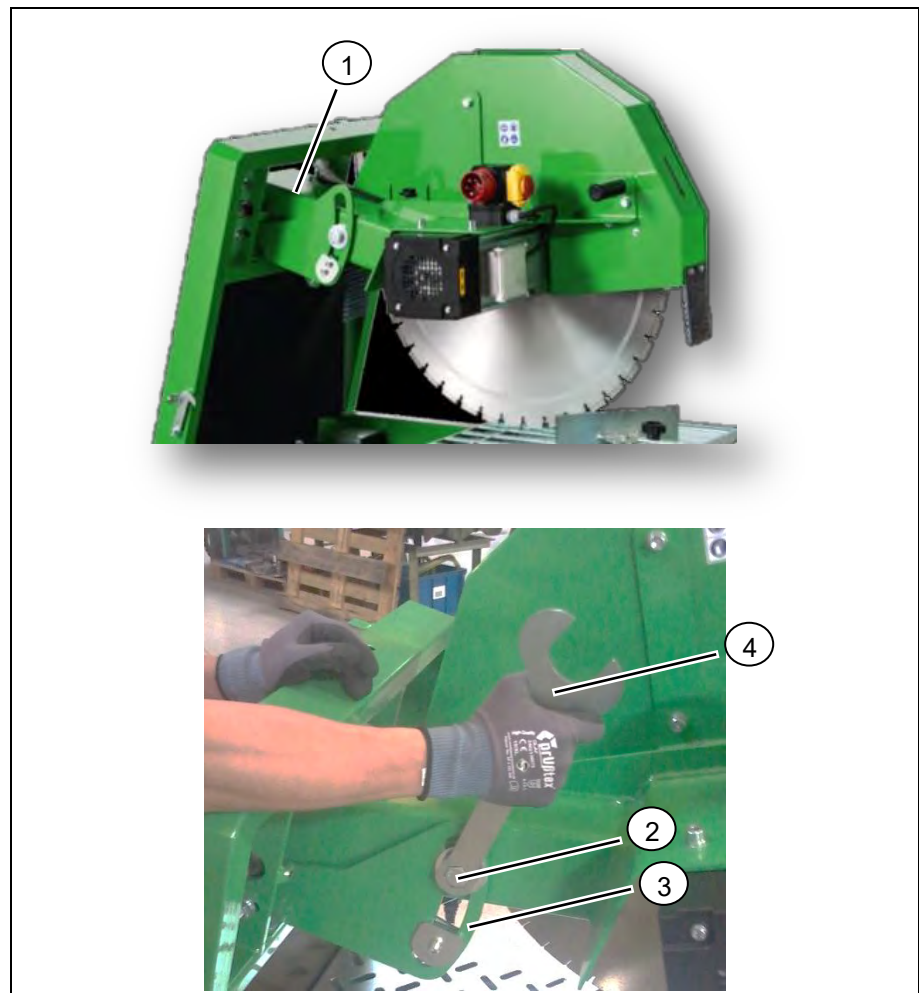

Figure 7: Cutting head adjustment

5.3 Operating and display elements

Switchbox

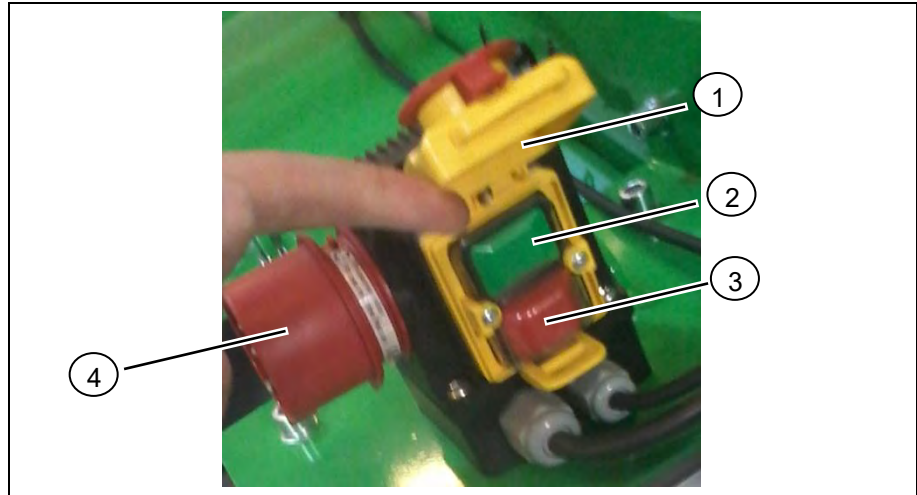

Figure 8: Controls on the switchbox

- | | | | |
|---|---|---|---------------------------|
| 1 | Main switch with emergency off function | 2 | On button green 1 |
| 3 | Off button red 0 | 4 | Socket - mains connection |

Block saw BS-750

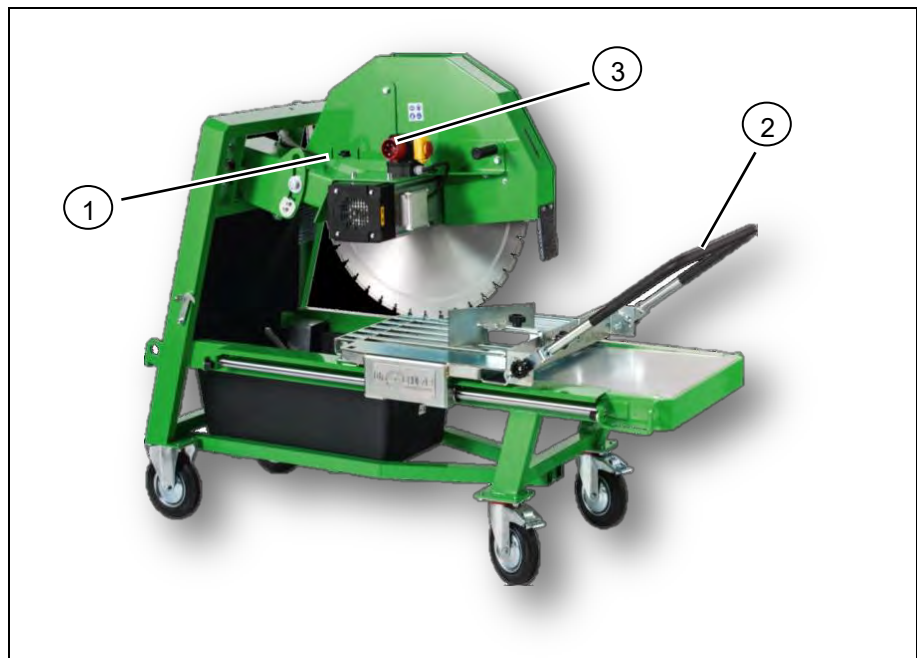

Figure 9: Operating elements of the Block saw BS-750

- | | | | |
|---|---|---|-----------------|
| 1 | Shut-off valve of the cooling water supply to the cutting blade | 3 | Manual guidance |
| 2 | Socket - mains connection with phase inverter | | |

6 Transport and storage

6.1 Delivery

Upon delivery of the machine, the following parts / components are included:

Table 4: Delivery

Title	Order number
Block saw BS-750 with the original operating instructions	MS 15000 837

6.2 Transport



Attention

Serious damage to the transport equipment and the property nearby can result from incorrect transport.

- When loading and unloading and transporting goods within the plant, always proceed with the utmost care and caution.
- Observe the notices and symbols on the packaging.
- Only transport the machine with the transport lock installed.
- Always remove the transport lock during assembly.

The transport product is packaged securely and environmentally for the expected transport conditions. The packaging protects the parts until the start of installation against damage and corrosion.

The goods to be transported are delivered by a forwarding agency and can be brought to the place of use by means of a forklift truck. Transport may only be carried out by specially qualified personnel.

6.2.1 Transport inspection

Check the condition of the transport goods upon receipt of the delivery immediately for completeness and damage.

- Remove packaging and, if necessary, transport safety devices.
- Dispose of packaging material in accordance with local/regional/statutory regulations.
- Check the painted surface of the machine for perfect condition.
- Check all plugs and connections for proper fit.
- Check the model number and serial number on the name label to see if it matches the delivery slip.



Note

Make a complaint about any defect to the freight forwarder responsible as soon as the transported goods are received! Claims for damages due to transport damage can only be asserted within the statutory claims period.

Where there is externally visible transport damage:

- Immediately notify the freight forwarder responsible for delivery in case of damage.
- Delivery is not accepted or subject to reservation.
- Entire the scale of the damage on the transport documents and mention it on the delivery note of the transporter.

6.2.2 Transport symbols

There are symbols on the transport product that correspond to the contents, which must be observed without fail during transport and storage.

The following transport symbols can appear on the transport product:



Above

The arrow points show the top of the transport product. They must point upwards, otherwise the contents can be damaged.



Protect from moisture

Protect the transport product from moisture and keep dry.



Attachment point

Only attach the lifting tackle at the marked positions.



Center of gravity

Indicates the center of gravity of the transport product.

Observe the position of the center of gravity during lifting and transport!

6.3 Transport in-plant

The Block saw BS-750 may be transported via the rollers (1) to the place of use. Before transport, the transport safety (2) device for the tray table must be installed.

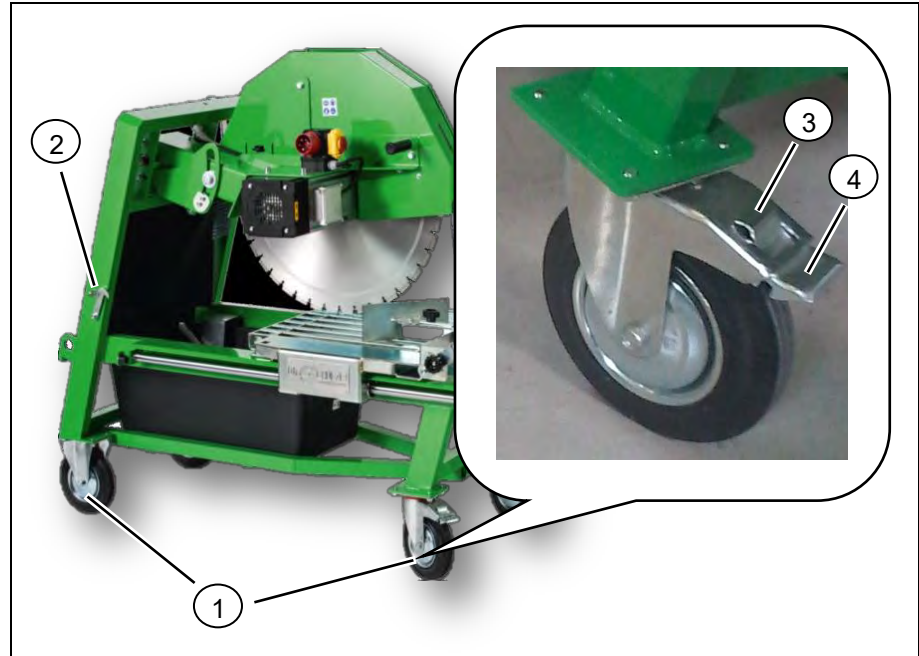

Figure 10: Release / tighten brake on rollers

1. Move the cutting table far enough that the transport safeguard engages.
2. Tighten the locking screw in the guide frame. As a result, the upper carriage is in the transport position and is secured there.
3. Release the brakes on the rollers (1) of the base by pushing down the catch at position (3).
4. Move the Block saw BS-750 to the desired location.
5. Push down the catches of the rollers (1) on the base frame at position (4). The brakes are on and the Block saw BS-750 may no longer be moved.

6.4 Storage

For the storage of the machine, it is necessary to place it according to the indoor environment defined under the storage conditions. Prior to storage, the machine must be properly cleaned, lubricated and dried in accordance with the instructions in the maintenance section, in order to protect it from corrosion.

6.4.1 Storage conditions

Only store the machine under the following conditions:

- Do not store in the open.
- Keep dry and free of dust.
- Do not apply any corrosive substances.
- Protect against sunlight.
- Avoid mechanical shocks.
- Storage temperature 5 °C to 45 °C
- Atmospheric humidity, max. 60 %

6.5 Handling packaging materials

Observe the following when handling the packaging material:

- Always dispose of packing in an environmentally responsible manner.
- Observe local/regional/applicable statutory regulations. Where necessary use a qualified firm for disposal.



Environmental damage due to incorrect disposal!

- Packaging materials are valuable raw materials and can be used again or usefully processed and re-used.

7 Setup

Any installation work may only be carried out by trained personnel authorized by the operator. For all installation work the necessary personal protective equipment (workwear, safety shoes) must be worn.

Work on the electrical connection may only be carried out by qualified electricians.

7.1.1 Notes on setup



Caution

Danger of tripping due to faulty routing of the energy supply!

The cables laid on the floor pose a risk of tripping and therefore falling.

- When setting up the machine, make sure that the energy supply is covered or marked accordingly.
- If possible, move the energy supply in such a way that it poses no danger to transport traffic and people.
- The surface on which work takes place must: have sufficient load-bearing capacity, be non-slip, be horizontal and even or not exceed an inclination of 5 %.

7.2 Electrical connection



Danger

Danger of injury due to electrical voltage!

There is a risk of injury when touching live parts.

- All electrical connection work may only be performed and inspected and approved by trained electricians.
- Live cables must not come into contact with water or water mist.

The electrical connection of the machine may only be made via a suitable power distribution board. Portable machines used outdoors must be connected through a fault-current circuit breaker.

The Block saw BS-750 are subject to increased safety requirements for wet operation.

Make sure that the machine is always grounded.

Do not use any adapters on the machine. Only use extension cords that meet the requirements of the Block saw BS-750 and the installation site (cross-section, insulation, etc.).

1. Check whether the mains voltage matches with the machine data (see section).
2. Check whether a correctly laid ground cable is available.
3. Connect the Block saw BS-750 to the mains according to the prescribed electrical specifications (400 V, 20 A, 3 phases + ground) via the socket for the mains connection.

8 Operation

Any operation may only be carried out by trained personnel authorized by the operator. When working with the machine, wear the necessary personal protective equipment (protective clothing, safety shoes, protective gloves, hairnet, ear protection, face protection).

When working outdoors, rubber gloves and non-slip safety shoes are recommended in particular.

8.1 Notes on operation



Warning

Risk of injury due to improper operation!

The machine may only be operated with mounted protective devices, otherwise there is a risk of injury.

- Ensure before all work that the safety systems are correctly installed and function without error. Never disable safety equipment.
- Responsibilities of the operator, installation of safety systems (RCD) that detect a short-circuit and isolate all connected phases.



Caution

Risk of injury due to loose parts!

An improperly installed cutting blade may loosen during operation.

- Before each operation, check whether the cutting blade is firmly and centrally mounted.
- Check that the blade guard is mounted correctly.



Caution

Danger of injury due to loose workpieces!

Loose workpieces can be ejected uncontrollably during the cutting process.

- Always clamp the workpiece firmly on the storage table.
- Manual holding of workpieces is prohibited.

8.2 Clamping / changing the cutting blade



Caution

Danger of cutting by the cutting blade!

There is a risk of cutting when touching the cutting blade.

- Wear resistant gloves when mounting and changing the cutting blade.
- Isolate the machine from electrical current!
- Only cutting discs approved by the manufacturer and labelled as such may be used for dry cutting. Acute risk of injury arises from the use of unsuitable cutting discs.



Attention

The bore diameter of the cutting blade must match the receiving diameter of the driver flange.

The driver flange and cutting blade must be clean.

An eccentric clamping of the cutting blade will lead to damage to the machine, workpiece and cutting blade.

- Clean the driver flange and the cutting blade before clamping.
- After clamping, check the firm and central position of the cutting blade.



Figure 11: Open blade guard

1. Loosen the screw (1) and remove the blade guard (2).

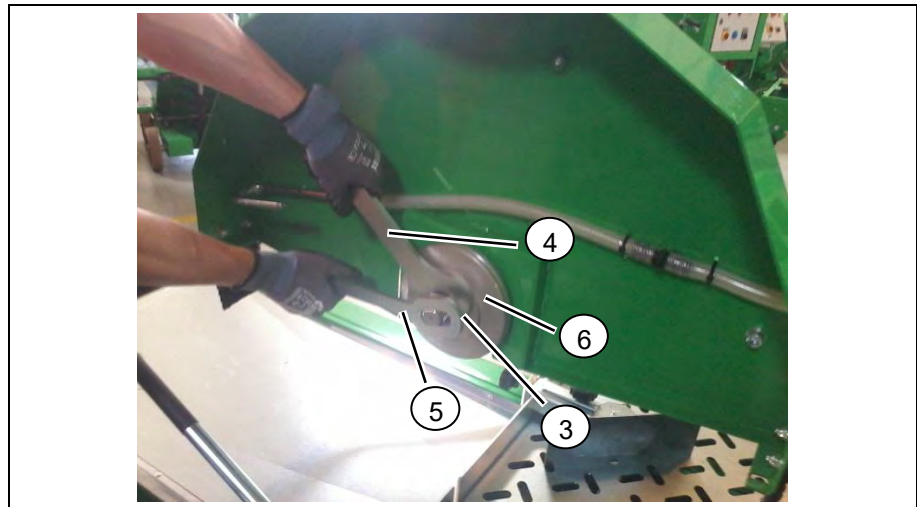

Figure 12: Mounting the cutting blade

2. First release the nut (3) using the tools supplied (spanner 46/24 (4) and ring-elongated hole spanner 20/13 (5)) and then unscrew it. To release it, hold the cutting shaft fast with the second tool supplied (ring-elongated hole spanner 20/13 (5)).
3. Remove the outer driver flange (6) from the shaft.
4. Take off the cutting blade from the shaft to change it.
5. Clean the driver flange (6) and the saw blade (7) to be clamped carefully.

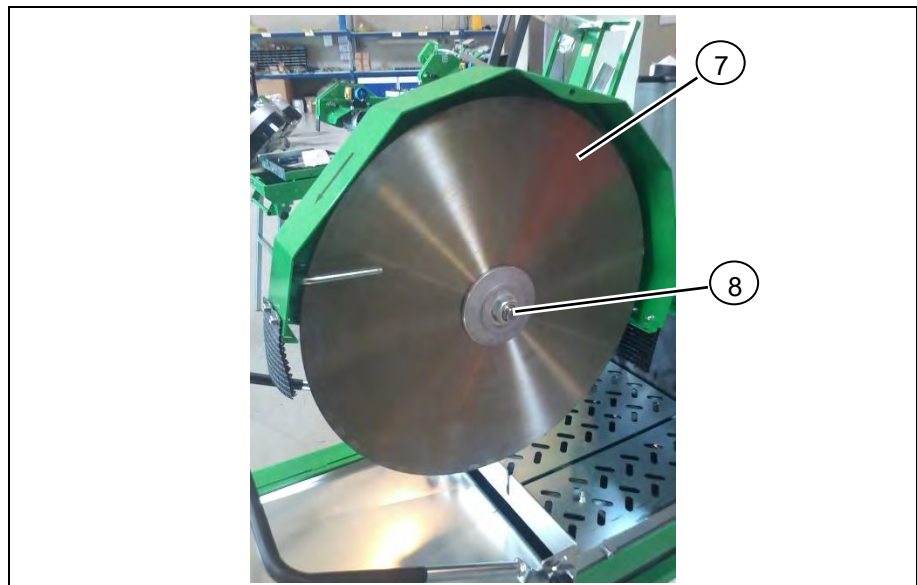

Figure 13: Mounting the cutting blade

6. Place the cutting blade (7) on the collar (8) of the inner driver flange.



Note

Use only by Dr. Schulze GmbH-approved cutting blades.
The cutting disc used must always be appropriate for the material to be cut.

7. Put on the outer driver flange (6).
8. First attach the nut (3) and then do it up using the tools supplied (spanner 46/24 (4) and ring-elongated hole spanner 20/13 (5)). To tighten it, hold the cutting shaft fast with the ring-elongated hole spanner 20/13 (5) supplied.



Note

The cutting blade must turn to the left when looking at the outer flange. The direction of rotation indicated on the cutting blade must correspond to this direction of rotation.

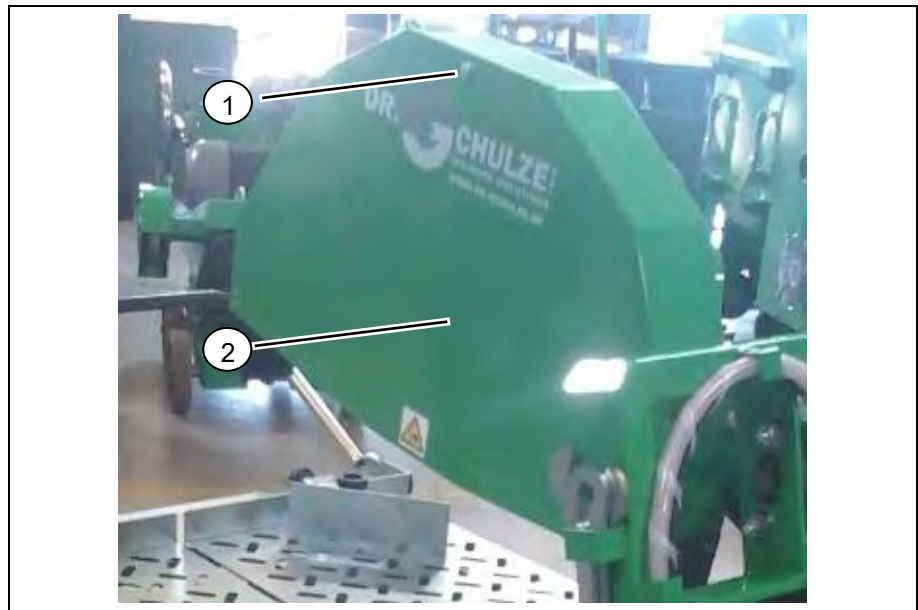

Figure 14: Mounting the blade guard

9. Close the blade guard (2) with the latches (1).

8.3 Filling the cooling water



Attention

If the cutting blade is not adequately supplied with cooling water during wet cutting, overheating may occur, leading to premature wear, failure or segment loss of the cutting blade.

- The outlet nozzle of the water hose on the blade guard must not be blocked.
- The water pump must not run dry.
- Check the level in the cooling water tank regularly and top up if necessary.
- If there is a risk of frost, drain the cooling water tub and open the shut-off valve.

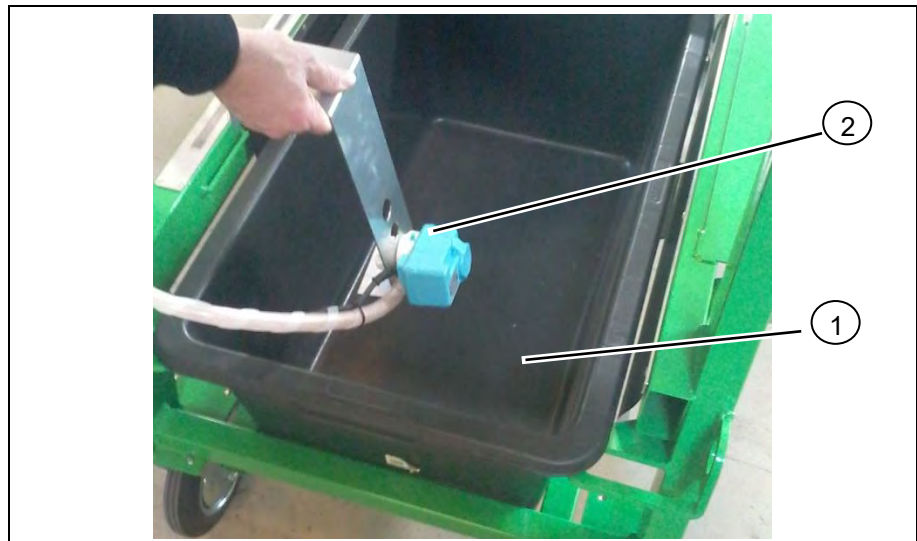

Figure 15: Water coolant tank with water pump

1. Fill the cooling water tank (1) with sufficient water (at least 10 cm above the bottom of the tank) so that the pump (2) can always be supplied.
2. Check that the shut-off valve is set correctly for each cut:
 - Wet cutting: Shut-off valve opened.
 - Dry cutting: Shut-off valve closed.



Note

When wet cutting, the rotating cutting blade must be sprayed with sufficient cooling water. You can regulate the amount of water via the shut-off valve.

8.4 Turn on the Block saw BS-750

1. Make sure that the cutting blade is in perfect condition as well as fixed and centered.
2. Make sure the blade guard is closed.
3. Check the level of cooling water and the position of the shut-off valve.
4. Connect the power at the mains plug (1)

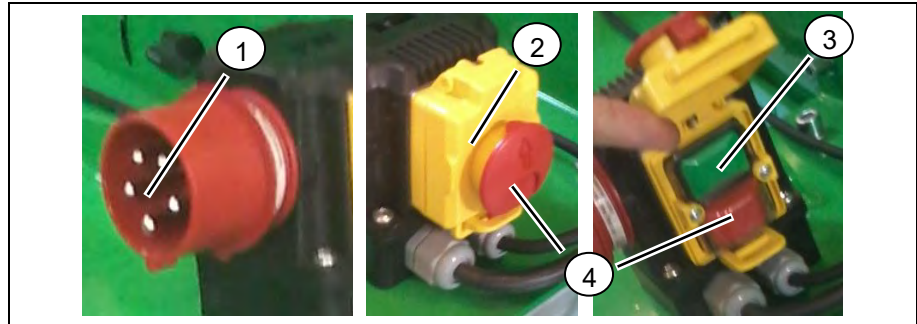

Figure 16: Turn on the Block saw BS-750

5. Open the emergency off cover (2) of the main switch.
6. Press the green on button 1 (3)
7. Set the star-delta switch (1) to the “star” position.
8. Wait until the drive has reached its maximum speed.
9. Set the star-delta switch (1) to the “delta” position.
10. Check the rotary direction of the cutting shaft using the directional arrow on the blade protector.



Note

If the cutting disc is turning in the wrong direction, press the emergency off button (4). Disconnect the Block saw BS-750 from the mains connection. Then turn the plug-in integrated phase inverter (3) with a screwdriver.

After changing the direction of rotation, make the mains connection and repeat the switch-on procedure.

8.5 Cutting process



Warning

Danger of injury due to rotating cutting blade!

During operation, do not reach into the danger zone of the machine. In addition, the machine may only be operated with mounted protective devices.

- Ensure before all work that the safety systems are correctly installed and function without error.
- Do not reach into the running machine.



Figure 17: Cutting process

11. Move the cutting table using the manual guide (1) to the rear limit (2).
12. Place the workpiece on the cutting table (3) in such a way that it abuts the fixed stop rail (4). For angled cuts use the angle stop rail (5).
13. Switch the Block saw BS-750 on.

14. Switch on cutting disc cooling.
15. Move the cutting table with the workpiece by pushing the manual guide (1) towards the cutting disc.
16. Continue to push the cutting table forward until the workpiece has been split. Take care in doing so that the workpiece does not twist.
17. Once the cutting procedure is complete, retract the mobile sections to the rear limit.
18. Close the shut-off valve.
19. Switch the Block saw BS-750 off.
20. Remove the cut workpiece from the cutting table.

8.6 Switch Off

8.6.1 Pause

1. After the Mobile section has reached the rear stop, press the emergency stop button (1).



Figure 18: Turn off the Block saw BS-750

8.6.2 Shutdown

1. After the upper carriage has reached the rear stop again, press the emergency stop button (1).
2. Clean the Block saw BS-750 as described in section 9.3.



Figure 19: Turn off the Block saw BS-750

3. Empty the water coolant tank (2) and dispose of the dirtied coolant according to local rules and regulations. (Also see section 9.2.1)
4. For the machine at a longer standstill, remove the water pump (3) and clean it according to the manufacturer's instructions. (Also see section 9.2.1)



Note

For the water pump (3), Dr. Schulze GmbH offers no guarantee.
The water pump must be thoroughly cleaned after every use according to maintenance plan 9.2.1.

8.7 Shutdown in emergency

In case of danger:

5. Immediately press an emergency stop button.
6. Inform those in charge at the site.
7. If required, alert a doctor and the fire service.
8. Retrieve injured persons and apply first aid.
9. Disconnect the plug.
10. Keep the approaches for rescue vehicles free.

8.7.1 Measures before restarting after an emergency stop

After rescue measures:

1. Where required, contact the responsible authorities.
2. In the event of damage to the machine, have it repaired by qualified personnel.
3. Inspect the machine thoroughly before restarting for its technical condition to ensure that all functions are operating without faults.

8.8 Settings

8.8.1 Setting the cutting depth

The cutting head is held by a cutting head mount (1). The position of the cutting head can be set using the fixing screw (2) and the locking mechanism (3). This allows the cutting disc to be positioned for full or reduced cut depths. In this way, an even depth of cut can be guaranteed along the entire length. Use the tool supplied, spanner 46/24 (4), for this.

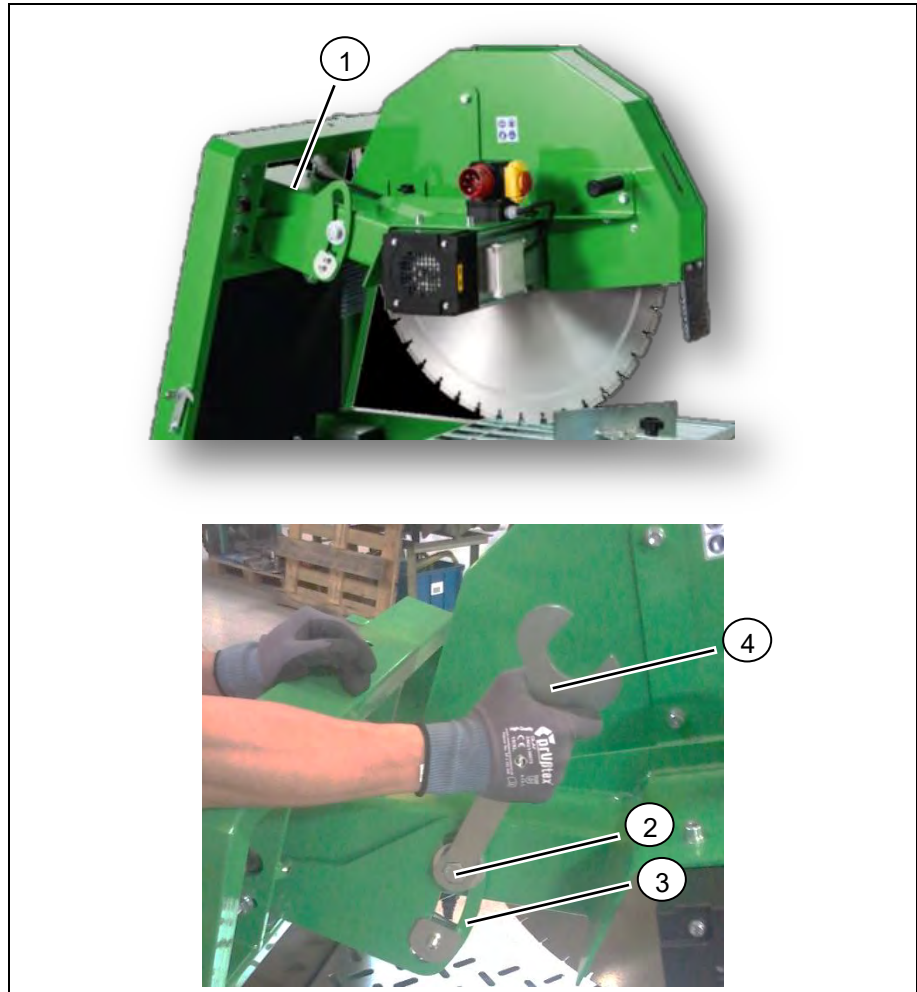

Figure 20: Setting the cutting depth

1. Undo the fixing screw (2) using the tool (4).
2. Move the cutting head with the cutting disc along the elongated hole on the locking mechanism (3) to achieve the desired cut depth (vertical position).
3. Affix the cutting head on the locking mechanism (3) using the fixing screw (2).

8.8.2 Adjusting the cutting blade

Tools required:



Abbildung 21: Cutting disc adjustment tool

- Set square
- Accessory tools for the machine
- 19mm spanner/ring spanner
- 17mm spanner/ring spanner
- 6mm Allen key

1- Isolate the machine from the power supply!



2- Releasing the screws of the cutting disc cover



3- Removing the protective cover



4- Release the flanged nut



5- Mount cutting disc



6- Fix cutting disc



7- Check cutting head angle



8- Adjust cutting head
- Loosening the bearing blocks

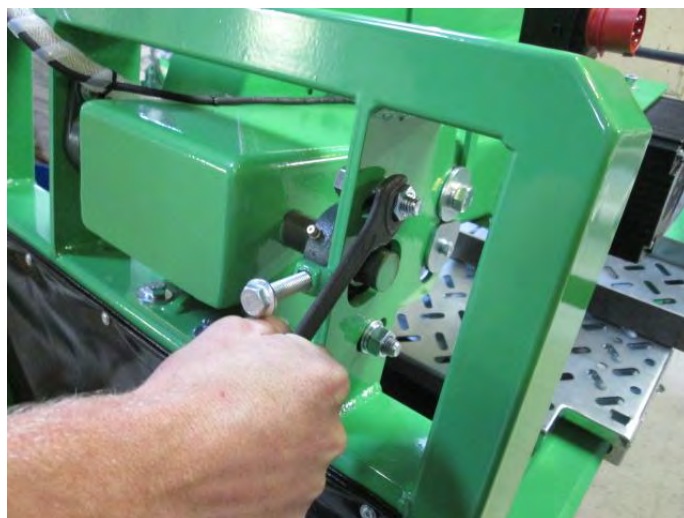

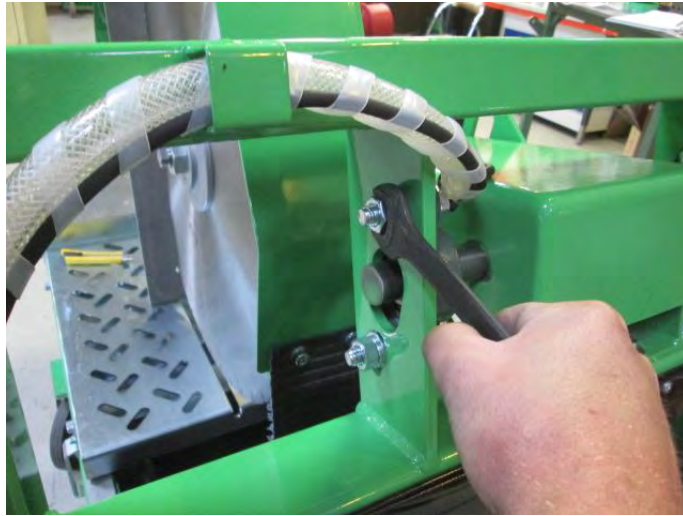

- Insert adjustment screw M10 x 70 mm into the threaded hole intended for it.



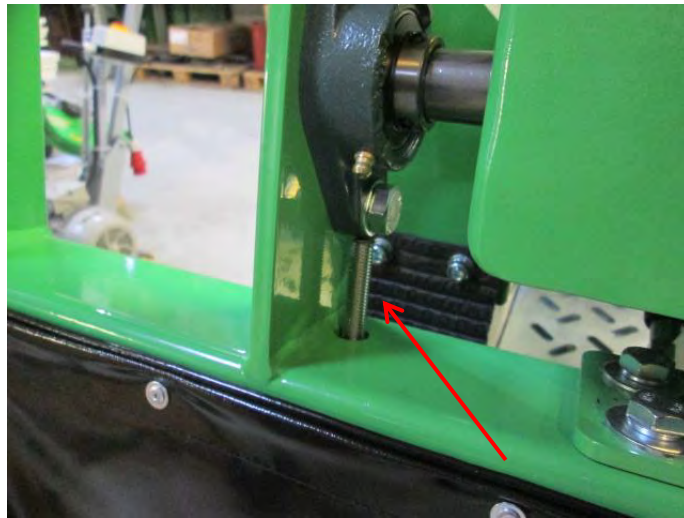

Screw in the adjustment screw up to the bearing blocks and then set these so that the angle is correct. Once the angle has been set, fix the bearing blocks and remove the adjustment screw.

9- Making the cutting disc parallel to the table

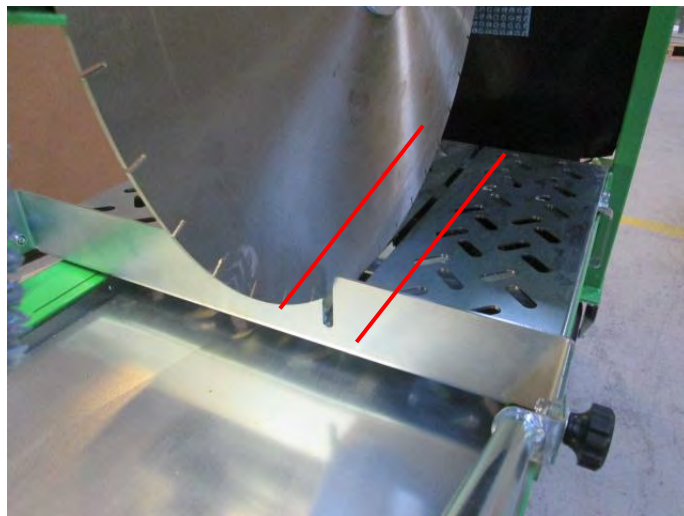

- Loosen the screw fixtures of the cutting table (front)



- Loosen the screw fixtures of the cutting table (rear)



- Move the table via the screws in such a way that it runs parallel to the cutting disc.



When the table runs parallel to the cutting disc, tighten the screws again.

9 Maintenance and cleaning

Any maintenance work may only be carried out by trained personnel authorized by the operator. All necessary personal protective equipment (workwear, safety shoes) must be worn during all maintenance work.

Work on the electrical connection may only be carried out by qualified electricians.

9.1 Maintenance

9.1.1 Notes on maintenance



Danger

Danger of injury due to electrical voltage!

There is a risk of injury when touching live parts.

- All electrical connection work may only be performed and inspected and approved by trained electricians.
- Before carrying out maintenance and repair work, switch off the power supply and secure it against being switched on again.
- Be careful not to damage the insulation when working on electrical lines and cables.
- Remove moisture from the parts.



Warning

Danger of injury due to unintentional startup of the machine!

Maintenance work may only be carried out with the power supply disconnected.

- Before any maintenance work, make sure that the machine is disconnected from the mains connection.

9.1.2 Maintenance plan

In the following sections the maintenance works are described, which are required for optimal and fault-free operation.

- If the regular inspections show signs of wear on the parts, shorten the service intervals based on the actual signs of wear.
- Document all maintenance in a maintenance log.
- In case of questions on the maintenance works and intervals contact the manufacturer.

Table 5: Maintenance plan

Interval	Maintenance work	Remarks
Before every operation	– Check screws for tightness.	The machine is subjected to vibrations during operation.
	– Check connection cable and plug for damage.	By qualified electricians.
	– Check protective devices for function and presence.	
	– Visual inspection of the cutting blade for wear.	If worn or damaged, replace the cutting blade. Always clamp a cutting blade that fits the workpiece.
After every use	– completely clean the water pump.	Use a suction strainer and rinse through with fresh water
At each cutting blade change	– Clean the driver flanges.	
8 h	– Visual inspection of the cooling water tank for deposition of slurry.	When the slurry has settled, clean the cooling water tank.
	– Visual inspection of the spray nozzles of the forks on deposits.	If the spray nozzles have become contaminated with deposits, clean them.
	– Clean the guide of the cutting table – If necessary, oil the chain.	
300 h	– Visual inspection of the handwheel shaft, rocker shaft and cutting shaft – If necessary, lubricate the bearings of the shafts via the grease nipple with 2-3 strokes.	
500 h	– Check bearing for wear. The service life is 500 to 1000 h	Bearings may only be replaced by the manufacturer. Please ask customer service.
3 months	– Check the entire drives and the electrical parts of the machine for correct setting and function.	The test should be carried out by the manufacturer or by an authorized representative.
annually, before first use	– Have the machine checked for electrical safety in accordance with VBG4 [Accident-prevention regulations], §5.	By qualified electricians. The test must be documented.

9 Maintenance and cleaning

9.1 Maintenance



Table 5: Maintenance plan

Interval	Maintenance work	Remarks
See manufacturer's instructions	– Maintenance work on the water pump	For information, please refer to the manufacturer's instructions

9.1.3 Measures after Maintenance is Carried Out

After completing the maintenance and before turning on the machine, perform the following steps:

1. Check all previously loosened screw connections for tightness.
2. Check that all previously removed guards and covers are properly reinstalled.
3. Make sure that all electrical safety devices (e.g. emergency stop buttons) are working properly.

9.2 Maintenance work



Attention

Only original spare parts may be used.

Other parts can influence the safety functions and the behavior of the machine.

9.2.1 Emptying the cooling water tank

The water pump (1) can be mounted using the mounting bracket (2) in the water coolant tank (3).

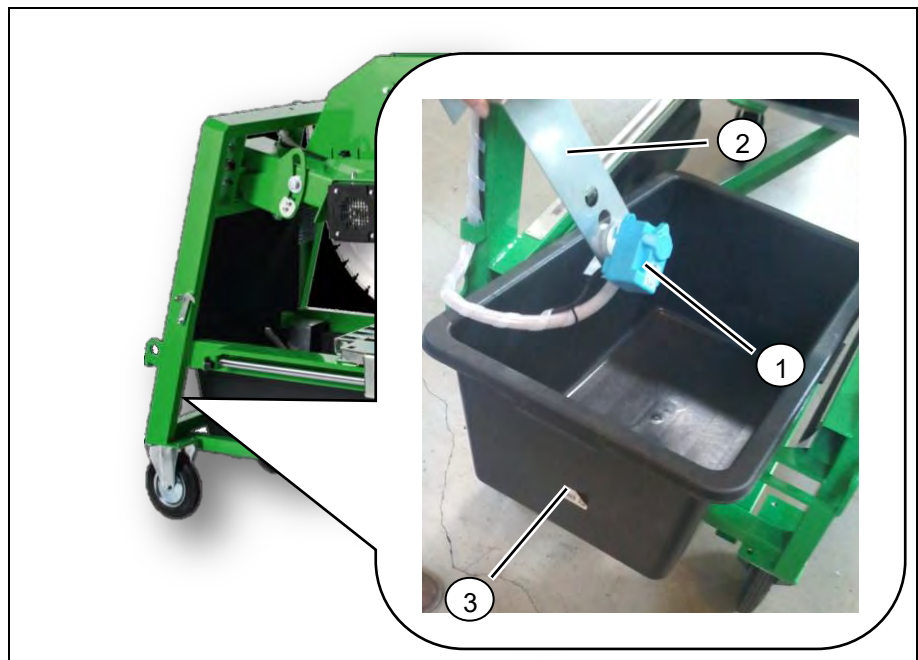

Figure 22: Draining the cooling water tank

1. Remove the water pump (1) from the water coolant tank (3). The water pump (1) can be removed from the water coolant tank (3) using the mounting bracket (2).
2. Two people should remove the water coolant tank (2) from the machine.
3. Empty the water coolant tank (3) and dispose of the dirtied coolant according to local rules and regulations.
4. Clean the water coolant tank (3) with water.
5. If the machine is shut down for a long time, dismantle the water pump (3) and clean it according to manufacturer instructions.
6. Refill the water coolant tank (2) with water. It must be filled to 20 cm.

9.2.2 Clean the water fork



Figure 23: Clean the water fork

1. Open the blade guard by loosening the screw and removing the blade guard.
2. Remove the cutting blade (see section 8.2).
3. Loosen the screws (2) and remove the water fork (1).
4. Blow the water fork off with compressed air or clean it with water.
5. Reinsert the water fork and attach it with the screws.
6. Mount the cutting blade (see section 8.2).
7. Apply the blade protector and fasten it with the screws.

9.3 Cleaning



Caution

Danger due to aggressive cleaning agents!

The use of cleaning materials can lead to injuries to the skin or airways.

- When working with cleaning materials the national and local statutory regulations for environmental protection and disposal must be observed.
- Wear appropriate personal protective equipment.
- No cleaning materials containing solvents may be used.
- Observe the instructions in the safety data sheets for the cleaning material used.

9.3.1 Cleaning the machine

1. Turn off the machine.
2. Disconnect the mains connection.
3. Clean the machine with water.



Note

Make sure that no water gets into the control box.

4. Wait until the machine is dry.
5. Reconnect the machine. (See section 7.2)
The machine is ready for use again.

10 Faults

Faults may only be rectified by trained and authorized personnel. For all work, the necessary personal protective equipment (workwear, safety shoes) must be worn.

Work on the electrical connection may only be carried out by qualified electricians.

10.1 Actions in case of faults

Actions after the occurrence of a fault

In general, the following applies:

1. In the event of faults that pose an immediate danger to persons or property, immediately trigger the emergency stop button.
2. Switch off all power supplies and secure them against being turned back on.
3. Inform those in charge at the site.
4. Depending on the type of fault, report the fault to the responsible and authorized qualified engineer and have it resolved by them.

Action after remedying of a fault

1. Check all screw fittings for tightness.
2. Check whether all previously removed protective devices and covers have been properly installed again.
3. Ensure that all tools, materials and other equipment used are removed from the work area.
4. Clean the work area and remove any leaked substances, such as, for example, fluids, work substances or the like.
5. Make sure that all electrical safety devices (e.g. emergency stop buttons) of the system are working properly.

10.2 Process related faults

Table 6: Process related faults

Fault	Possible causes
The direction of rotation of the cutting blade is wrong.	The drive is incorrectly polarized. Turn the phases around at the phase inverter.
	Motor protection switch is closed in the control box.
The drive of the cutting head does not start.	The fuse of the mains connection is defective.
	The cable cross-section of the supply cable is too small.
	The supply cable is damaged.
	The drive is defective.
The drive does not have enough power or the thermal overload relay triggers.	The voltage of the mains connection does not match that of the motor.
	The supply cable is too long or has insufficient diameter.
Drive shuts off during the cutting process. The machine can be switched on again after a break.	The feed during the cutting process is too large.
	The cut takes place.
	The cutting blade is worn (dull).
	The cutting blade used does not fit the workpiece. The workpiece consists of overly hard material.
No cooling water on the cutting blade	The shut-off valve on the cooling water supply to the saw blade is closed.
	The level in the cooling water tank is too low
	The water forks or spray nozzles are clogged.
	The water pump is defective.
The cut takes place.	The cutting blade is not perpendicular to the cutting table.
	The cutting blade has come off.
	The cutting blade is worn (dull).
	The cutting table does not run straight forward on the guide.
The drive is running, but the cutting blade does not cut.	The cutting blade is worn (dull).
	The cutting blade used does not fit the workpiece. The workpiece consists of overly hard material.

11 Removal and disposal

11.1 Notes on removal and disposal



Caution

Risk of poisoning from grease and oil!

When working with oils and greases there is a risk of poisoning.

- Observe the safety data sheets from the supplier, use personal body protection equipment.

11.2 Disposal

This machine complies with Directive 2012/19/EU (WEEE) of 08/13/2012. The manufacturer undertakes to take back the associated equipment for disposal. The device should be delivered free of charge to Dr Schulze GmbH or the place of acceptance designated by the manufacturer. Abroad, the device shall be returned to the sales agents of Dr. Schulze GmbH.



Environmental damage due to incorrect disposal!

- Old devices contain valuable raw materials that can be reused or processed and recycled.

12 Indices

12.1 Table of Figures

Figure 1:	Machine areas on the Block saw BS-750	17
Figure 2:	Position of the emergency stop button on the Block saw BS-750	20
Figure 3:	Position of the blade guard on the Block saw BS-750	21
Figure 4:	Position of the control box on the Block saw BS-750	22
Figure 5:	Name plate	25
Figure 6:	Block saw BS-750	26
Figure 7:	Cutting head adjustment	27
Figure 8:	Controls on the switchbox	28
Figure 9:	Operating elements of the Block saw BS-750	28
Figure 10:	Release / tighten brake on rollers	31
Figure 11:	Open blade guard	37
Figure 12:	Mounting the cutting blade	38
Figure 13:	Mounting the cutting blade	38
Figure 14:	Mounting the blade guard	39
Figure 15:	Water coolant tank with water pump	40
Figure 16:	Turn on the Block saw BS-750	41
Figure 17:	Cutting process	42
Figure 18:	Turn off the Block saw BS-750	44
Figure 19:	Turn off the Block saw BS-750	45
Figure 20:	Setting the cutting depth	47
Abbildung 21:	Cutting disc adjustment tool	48
Figure 22:	Draining the cooling water tank	59
Figure 23:	Clean the water fork	60
Figure 24:	Circuit diagram	69
Figure 25:	Replacement parts list	70
Figure 26:	Replacement parts list	71
Figure 27:	Replacement parts list	72
Figure 28:	Replacement parts list	73
Figure 29:	Replacement parts list	74

12.2 List of tables

Table 1: Version status	5
Table 2: Environmental conditions	24
Table 3: Technical data of the Block saw BS-750	24
Table 4: Delivery	29
Table 5: Maintenance plan	57
Table 6: Process related faults	63

13 Annex

- Appendix 1: Conformity Statement
- Appendix 2: Circuit diagram
- Appendix 3: Replacement parts list

13 Annex

13.1 Declaration of conformity within the meaning of the Machinery Directive 2006/42/EC Annex II 1A



13.1 Declaration of conformity within the meaning of the Machinery Directive 2006/42/EC Annex II 1A



Declaration of conformity within the meaning of the Machinery Directive 2006/42/EC Annex II 1A

We hereby confirm that the CE labelling process for the product listed below has been completed and has met the basic requirements of the EC Machinery Directive 2006/42/EC, EC Guideline for Electro-Magnetic Compatibility 2014/30/EU and the Outdoor-Guideline 2000/14/EC, guideline for environment-polluting sound emissions for devices and equipment designed for outdoor use. The protective regulations of the Low Voltage Directive 2014/35/EU have been met. In the event the equipment is modified without coordinating the modification process with us, this declaration is no longer valid. A complete list of the applied standards, guidelines and specifications as well as complete technical documentation is available at the manufacturers.

Manufacturer:	Dr. Schulze s.r.o. Hulinská 1814/1b 767 01 Kroměříž Czech Republic Tel.: +420 573 336 101
Provider of Documentation:	Dr. Schulze s.r.o. Hulinská 1814/1b 767 01 Kroměříž Czech Republic Tel.: +420 573 336 101
Machine:	Block saw BS-750
Serial Number:	See name plate
Applied Standards:	DIN EN 12418 Stone cutting equipment for use at construction sites – safety DIN EN ISO 12100 Equipment safety – general design guidelines – risk assessment and risk reduction. DIN EN ISO 13857 Equipment safety – safety distance for approaching hazardous areas with the upper and lower extremities. DIN EN ISO 14120 Equipment safety – separation safety guards – general requirements for the design and construction of stationary and mobile separation safety guards. DIN EN ISO 13850 Equipment safety – emergency stop – design sets. DIN EN 349 Minimum distance to prevent contusions of body parts. DIN EN 60204-1 Electrical equipment for industrial machines

767 01 Kroměříž June 08, 2018

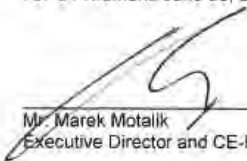
Mr. Marek Motalik
Executive Director and CE-Representative

13.2 Circuit diagram for the Block saw BS-750

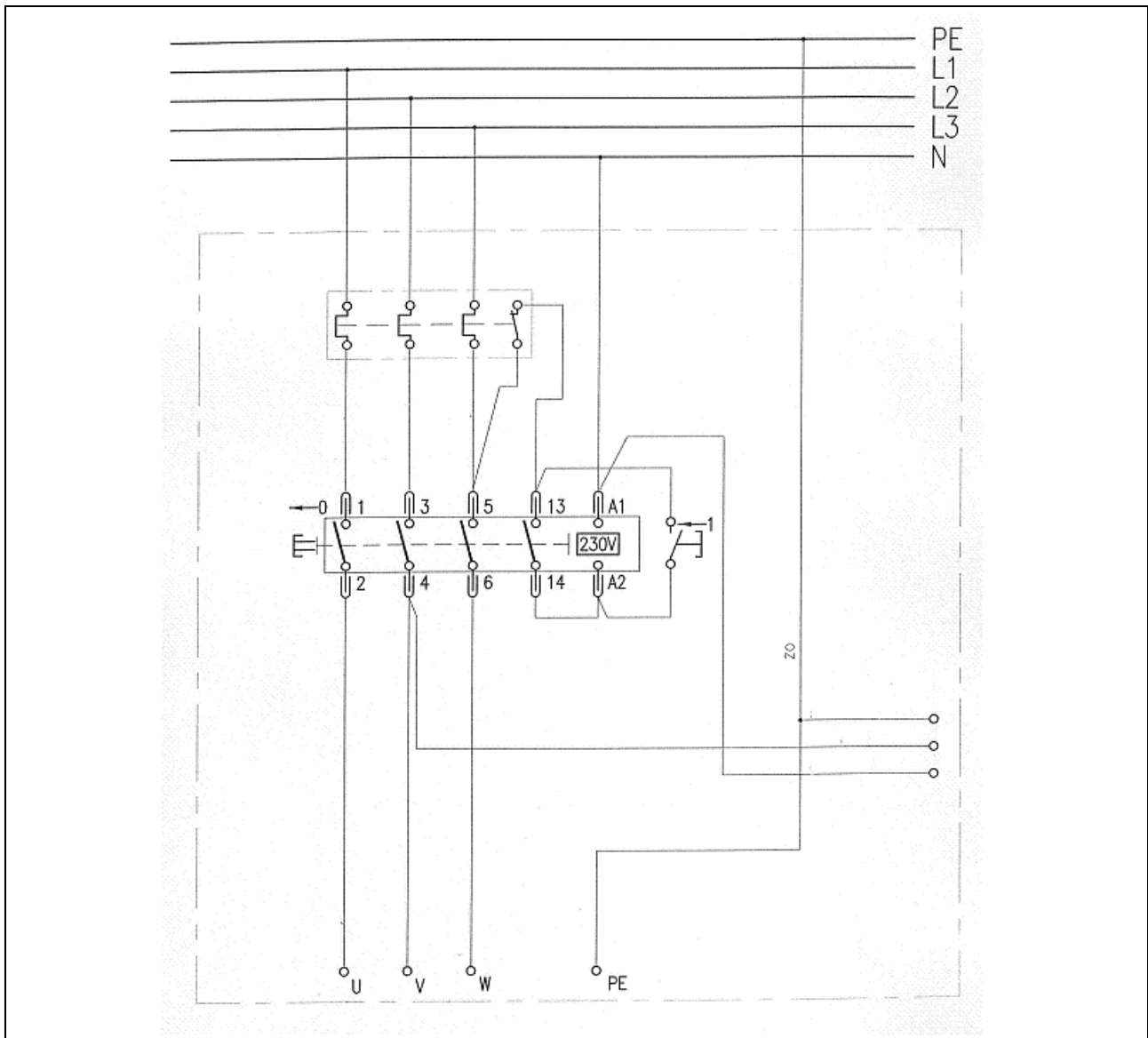

Figure 24: Circuit diagram

13.3 Replacement parts list

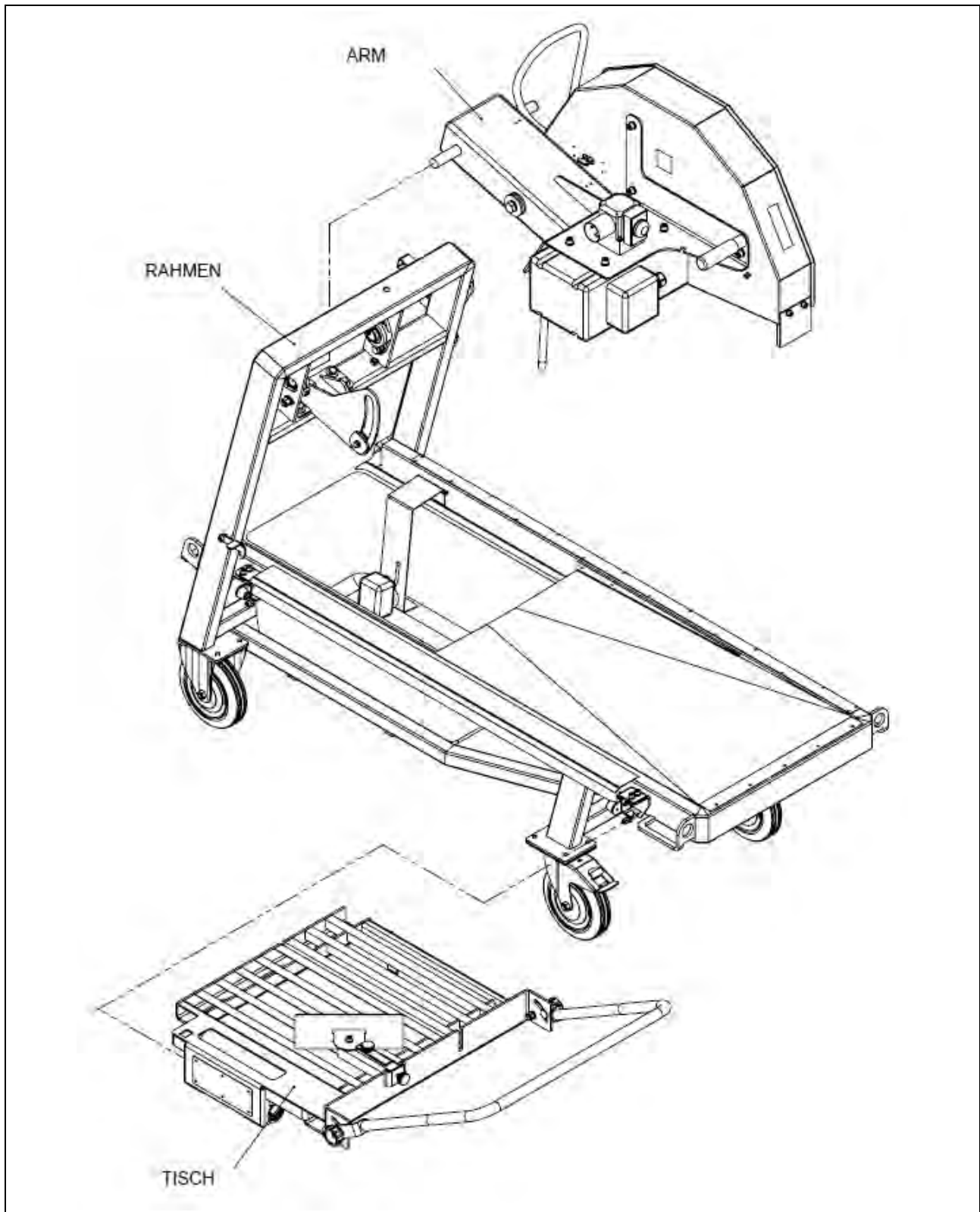

Figure 25: Replacement parts list

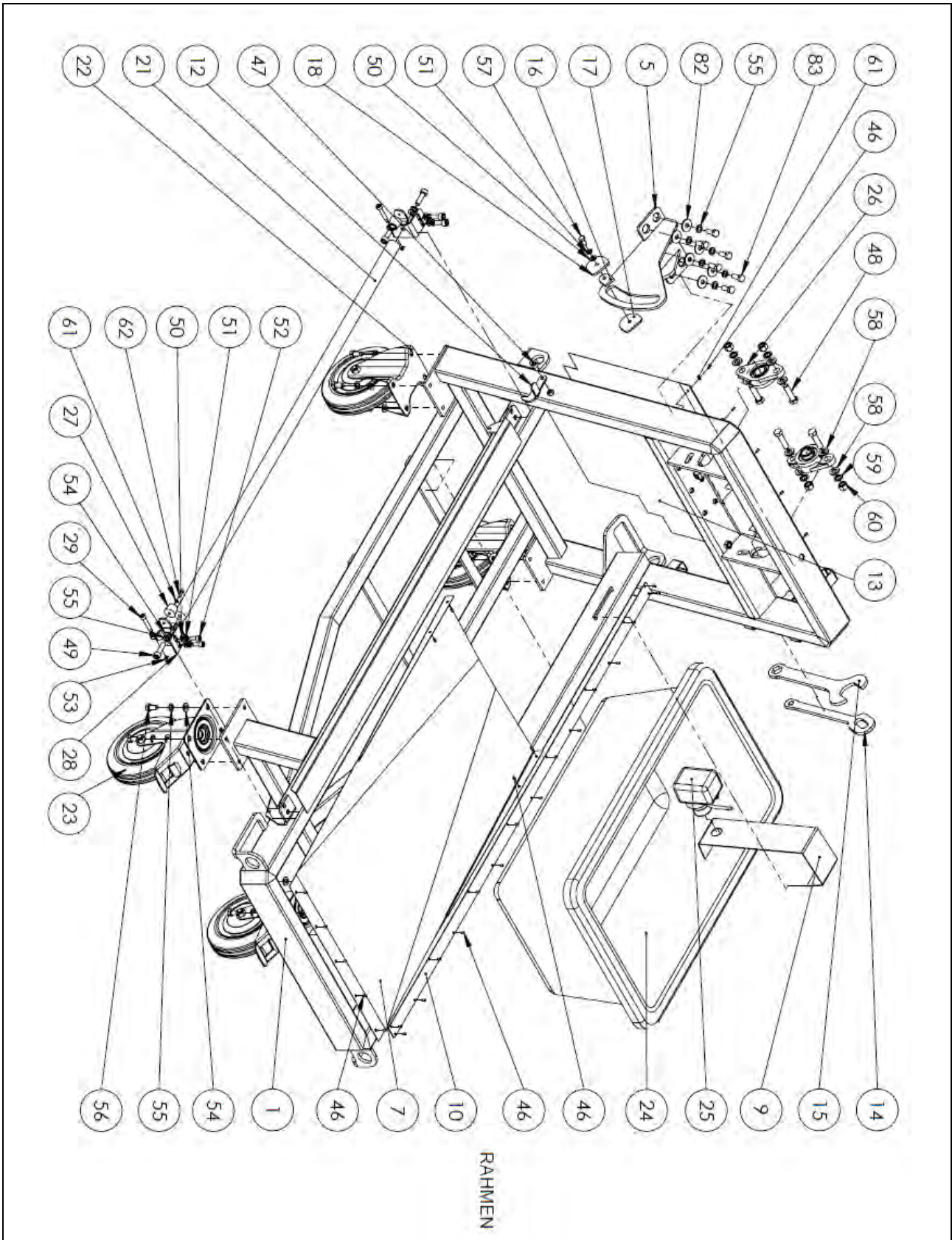

Figure 26: Replacement parts list

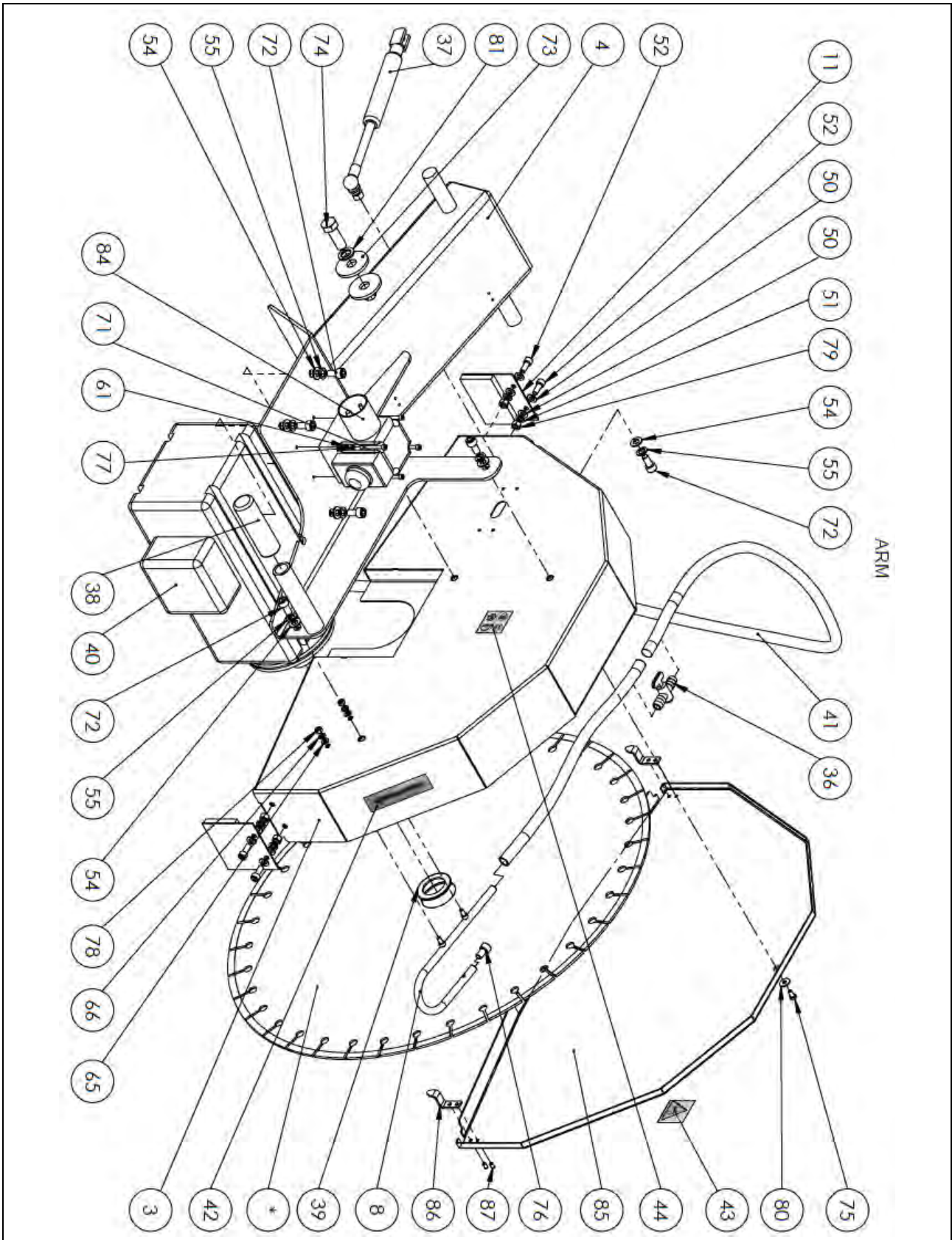

Figure 28: Replacement parts list

Item No.	Name	Item No.	Name
3	Disc cover	45	Protractor
4	Motor holder	46	Rivet 4X8
5	Console	47	Screw
6	Handle	48	Screw
7	Tank	49	Screw
8	Disc cooling	50	Washer 8.4
9	Pump holder	51	Spring washer 8
10	Sliding plate	52	Screw M10 x 35
11	Splash guard	53	Washer 8.4
12	Table lock	54	Spring washer 8
13	Apron	55	Screw M8 x 20
14	Spanner	56	Screw
15	Spanner	57	Screw
16	Limit stop	58	Washer
17	Limit stop 2	59	Spring Washer
18	Limit stop 3	60	Nut
19	Grease nipple	61	Washer 13
20	Hook	62	Washer 12
21	Guide bar	63	Nut M12
22	Fixed wheel	64	Washer 5.3
23	Rotating wheel	65	Washer
24	Drip tray	66	Screw M10x35
25	Pump	67	Sawing ring
26	Bearing	68	Washer 6.4
27	Rubber limit	69	Nut
28	Adjustment strap	70	Screw
29	Adjustment screw	71	Locking nut M10
30	Adjustment strap	72	Screw
31	Plastic nut	73	Washer
32	Ball bearing	74	Screw M5 x 45
33	Bearing	75	Screw M10 x 20
34	Heat-shrink tubing	76	Screw
35	Logo	77	Screw M16 x 45
36	Hose valve	78	Screw M6 x 12-WN
37	Gas pressure damper	79	Screw M10 x 16
38	Handle	80	Spring washer 5
39	Reducing ring D60/40	81	Spring washer 8
40	Motor	82	Nut M8
41	Coolant tube	83	Screw
42	Arrow sticker	84	Switch
43	Sticker	85	Protection cover
44	Sticker	86	Hook

Figure 29: Replacement parts list